

Features

- ESD / transient protection of high speed data lines
 - IEC 61000-4-2 (ESD): ± 30 kV (air), ± 30 kV (contact)
- Working voltage: $V_{RWM} = 3.3V$
- Low reverse clamping voltage

HF

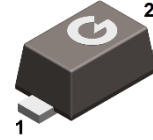
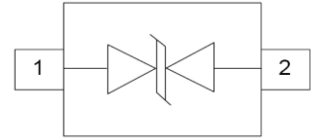

SOD-523

Mechanical Data

- Case: SOD-523
- Molding Compound: UL Flammability Classification Rating 94V-0
- Terminals: Matte tin-plated leads; solderability-per MIL-STD-202, Method 208

Ordering Information

Part Number	Package	Shipping Quantity	Marking Code
GESD3V3B5	SOD-523	3000 pcs / Tape & Reel	N3

Maximum Ratings (@ $T_A = 25^\circ C$ unless otherwise specified)

Parameter	Symbol	Value	Unit
IEC 61000-4-2; ESD (Air)	V_{ESD-A}	± 30	kV
IEC 61000-4-2; ESD (Contact)	V_{ESD-C}	± 30	kV
Peak Pulse Power ($t_p = 8/20\mu s$)	P_{PP}	270	W
Peak Pulse Current ($t_p = 8/20\mu s$)	I_{PP}	18	A

Thermal Characteristics

Parameter	Symbol	Value	Unit
Thermal Resistance Junction-to-Air ^{*1}	$R_{\theta JA}$	250	$^\circ C/W$
Thermal Resistance Junction-to-Case ^{*1}	$R_{\theta JC}$	170	$^\circ C/W$
Thermal Resistance Junction-to-Lead ^{*1}	$R_{\theta JL}$	180	$^\circ C/W$
Junction Temperature	T_J	-40 ~ +150	$^\circ C$
Storage Temperature Range	T_{STG}	-40 ~ +150	$^\circ C$

Note 1: The data tested by surface mounted on a 1 inch² FR-4 board with 2OZ copper

Electrical Characteristics (@ $T_A = 25^\circ\text{C}$ unless otherwise specified)

Parameter	Symbol	Test Condition	Min.	Typ.	Max.	Unit
Reverse Stand-off Voltage	V_{RWM}		-	-	3.3	V
Reverse Breakdown Voltage	$V_{(BR)}$	$I_T = 5\text{mA}$	4	-	6	V
Reverse Leakage Current	I_R	$V_{RWM} = 3.3\text{V}$	-	-	1	μA
Clamping Voltage	V_C	$I_{PP} = 1\text{A}, t_p = 8/20\mu\text{s}$	-	-	7	V
		$I_{PP} = 18\text{A}, t_p = 8/20\mu\text{s}$	-	-	15	V
Junction Capacitance	C_J	$V_R = 0\text{V}, f = 1\text{MHz}$	-	-	50	pF

Ratings and Characteristic Curves (@ $T_A = 25^\circ\text{C}$ unless otherwise specified)

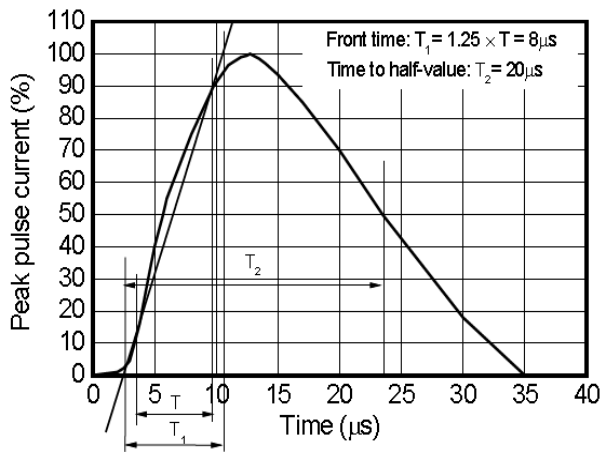

Fig 1 8/20 μs waveform per IEC61000-4-5

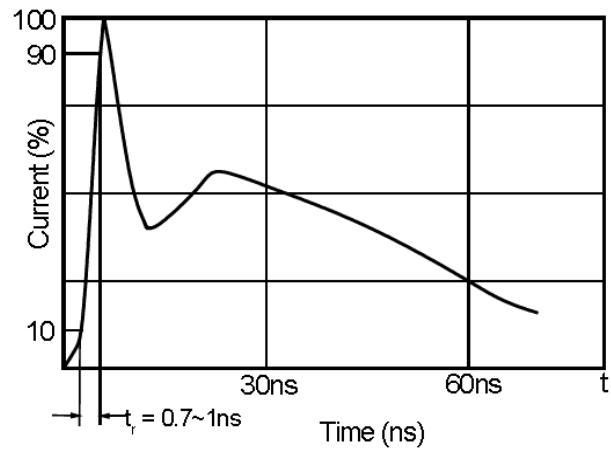

Fig 2 ESD pulse waveform according to IEC61000-4-2

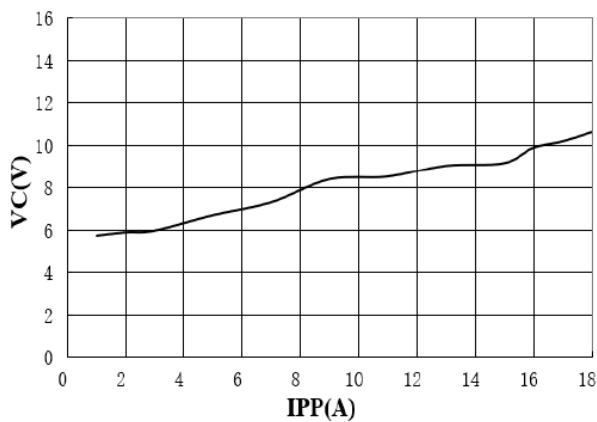
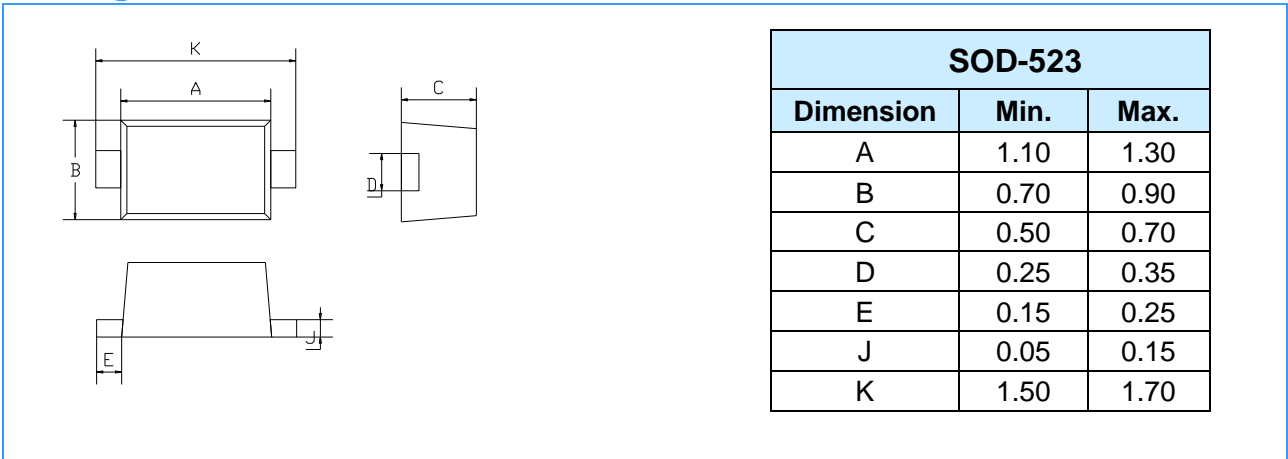
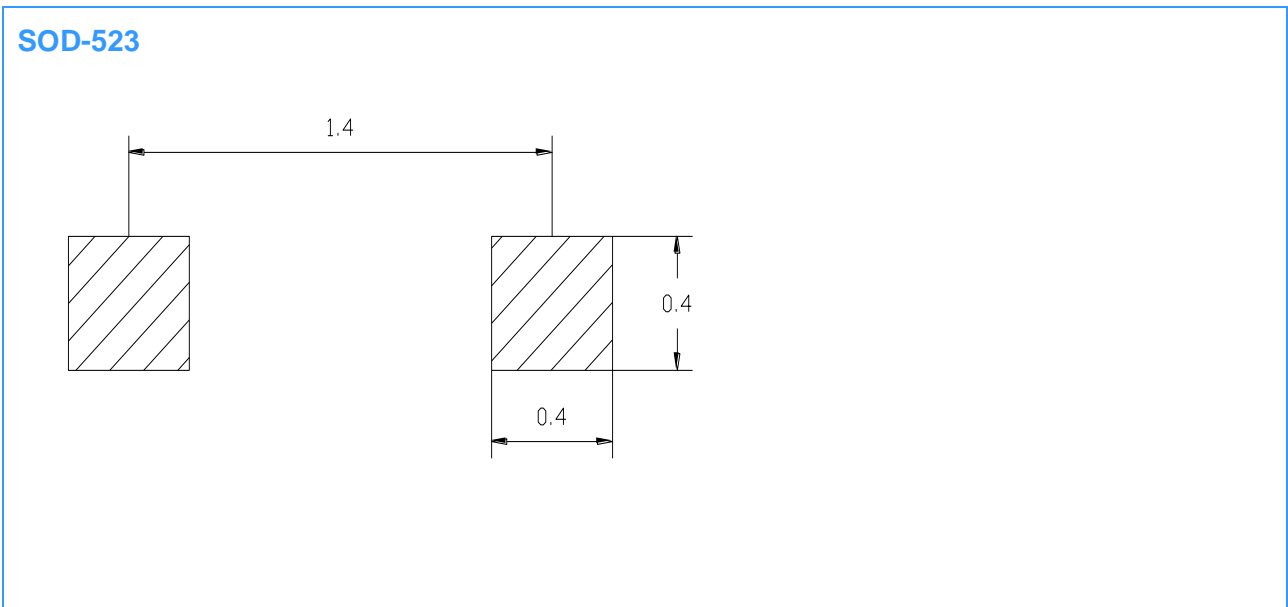

Fig 3 Clamping Voltage vs. Peak Pulse Current

Package Outline Dimensions (Unit: mm)



Package Outline Dimensions (Unit: mm)



IMPORTANT NOTICE

Changzhou Galaxy Century Microelectronics (GME) reserves the right to make changes without further notice to any product information (copyrighted) herein to make corrections, modifications, improvements, or other changes. GME does not assume any liability arising out of the application or use of any product described herein; neither does it convey any license under its patent rights, nor the rights of others.