

Features

- Advanced Shielded-Gate Trench technology
- Super low on-resistance
- Fast switching speed
- Excellent c_{dv} / d_t effect decline
- HBM: JESD22-A114-B: 1B
- RoHS compliant with Halogen-free

HF

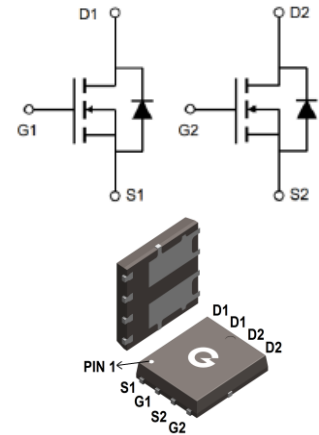

PDFN5x6-8LC

Mechanical Data

- Case: PDFN5x6-8LC
- Molding Compound: UL Flammability Classification Rating 94V-0
- Terminals: Matte tin-plated leads; solderability-per MIL-STD-202, Method 208

Ordering Information

Part Number	Package	Shipping Quantity	Marking Code
GBLN6607-5DL8	PDFN5x6-8LC	5000 pcs / Tape & Reel	GBLN6607

Maximum Ratings (@ $T_c = 25^\circ\text{C}$ unless otherwise specified)

Parameter	Symbol	Value	Unit
Drain-to-Source Voltage	V_{DSS}	60	V
Gate-to-Source Voltage	V_{GSS}	± 20	V
Continuous Drain Current ($T_c = 25^\circ\text{C}$)	I_D	33	A
Continuous Drain Current ($T_c = 100^\circ\text{C}$)		21	A
Continuous Drain Current ($T_A = 25^\circ\text{C}$) ^{*1}		9.5	A
Continuous Drain Current ($T_A = 100^\circ\text{C}$) ^{*1}		6	A
Pulsed Drain Current ($t_p = 10\mu\text{s}$, $T_c = 25^\circ\text{C}$)	I_{DM}	132	A
Single Pulse Avalanche Energy ^{*3}	E_{AS}	40	mJ
Power Dissipation ($T_c = 25^\circ\text{C}$)	P_D	25	W
Operating Junction Temperature Range	T_J	-55 ~ +150	$^\circ\text{C}$
Storage Temperature Range	T_{STG}	-55 ~ +150	$^\circ\text{C}$

Thermal Characteristics

Parameter	Symbol	Min.	Typ.	Max.	Unit
Thermal Resistance Junction-to-Case	$R_{\theta JC}$	-	-	5	$^\circ\text{C/W}$
Thermal Resistance Junction-to-Air ^{*1}	$R_{\theta JA}$	-	-	60	$^\circ\text{C/W}$

Electrical Characteristics (@ $T_A = 25^\circ\text{C}$ unless otherwise specified)

Symbol	Parameter	Test Condition	Min.	Typ.	Max.	Unit
Static Characteristics						
V_{DSS}	Drain-Source Breakdown Voltage	$V_{GS} = 0V, I_D = 250\mu A$	60	-	-	V
I_{DSS}	Zero Gate Voltage Drain Current	$V_{DS} = 48V, V_{GS} = 0V$	-	-	1	μA
I_{GSS}	Gate-Body Leakage Current	$V_{GS} = \pm 20V, V_{DS} = 0V$	-	-	± 100	nA
On Characteristics						
$R_{DS(ON)}$	Drain-Source On-resistance ^{*2}	$V_{GS} = 10V, I_D = 20A$	-	-	12	m Ω
		$V_{GS} = 4.5V, I_D = 15A$	-	-	16	m Ω
$V_{GS(th)}$	Gate Threshold Voltage	$V_{DS} = V_{GS}, I_D = 250\mu A$	1	1.8	2.5	V
R_G	Gate Resistance	$V_{GS} = 0V, f = 1MHz$	-	2.5	-	Ω
Dynamic Characteristics						
C_{ISS}	Input Capacitance	$V_{GS} = 0V$ $V_{DS} = 30V$ $f = 1.0MHz$	-	1246	-	pF
C_{OSS}	Output Capacitance					
C_{RSS}	Reverse Transfer Capacitance					
Switching Characteristics						
$t_{d(ON)}$	Turn-on Delay Time	$V_{DD} = 30V$ $V_{GS} = 15V$ $I_D = 20A$ $R_G = 3.3\Omega$	-	7	-	ns
t_r	Turn-on Rise Time					
$t_{d(OFF)}$	Turn-Off Delay Time					
t_f	Turn-Off Fall Time					
Q_G	Total Gate-Charge	$V_{DD} = 15V$ $V_{GS} = 10V$ $I_D = 20A$	-	23.8	-	nC
Q_{GS}	Gate to Source Charge					
Q_{GD}	Gate to Drain (Miller) Charge					
Source-Drain Diode Characteristics						
V_{SD}	Diode Forward Voltage ^{*2}	$I_{SD} = 20A, V_{GS} = 0V$ $dI/dt = 100A/\mu s$	-	0.9	1.2	V
t_{rr}	Reverse Recovery Time		-	37	-	ns
Q_{rr}	Reverse Recovery Charge		-	31	-	nC
I_{rr}	Reverse Recovery Current		-	1.6	-	A

Notes:

- The data tested by surface mounted on a 1 inch² FR-4 board with 2OZ copper
- The data tested by pulsed, pulse width $\leq 300\mu s$, duty cycle $\leq 2\%$
- The E_{AS} data shows Max. rating. The test condition is $V_{DD} = 25V, V_{GS} = 10V, L = 10mH$

Ratings and Characteristics Curves (@ $T_A = 25^\circ\text{C}$ unless otherwise specified)

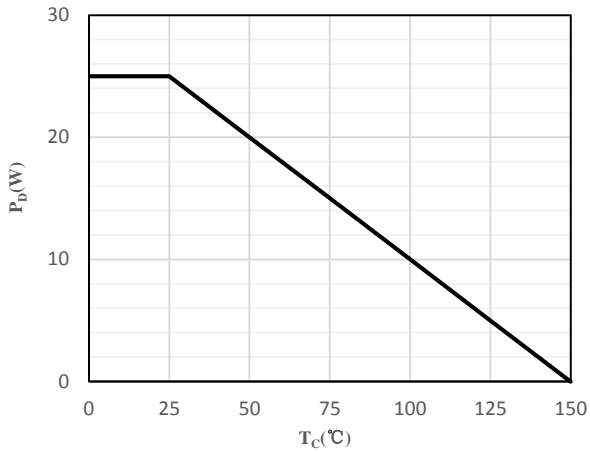

Fig 1 Power Dissipation

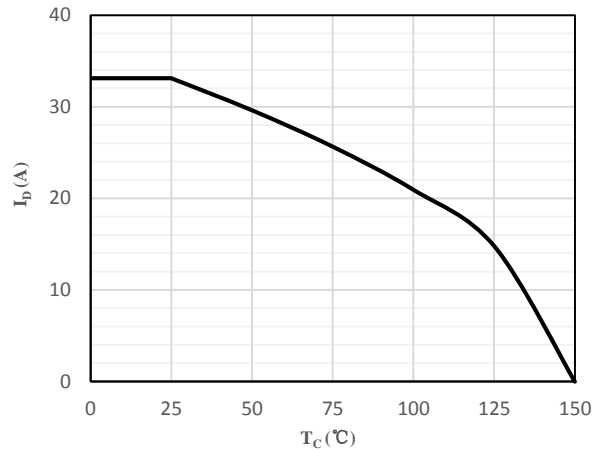

Fig 2 Drain Current

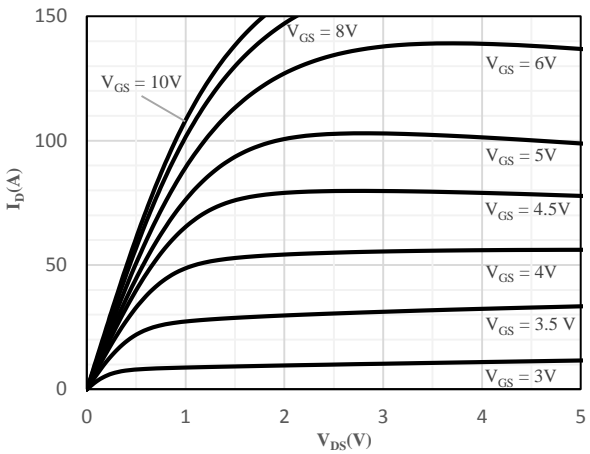

Fig 3 Typical Output Characteristics

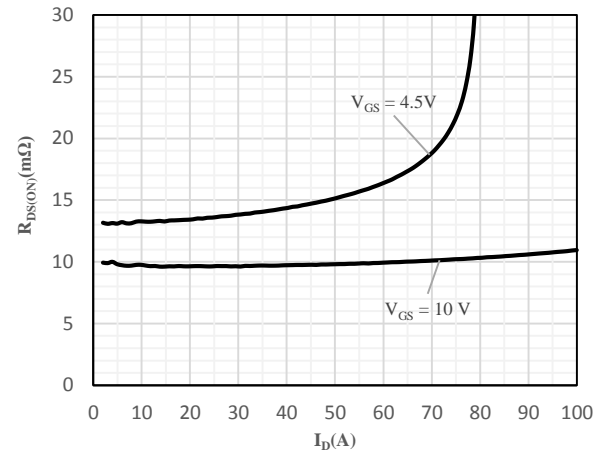

Fig 4 On-Resistance vs. Drain Current and Gate Voltage

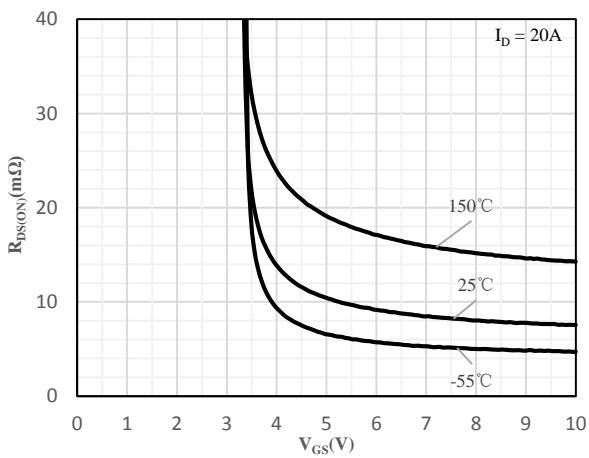

Fig 5 On-Resistance vs. Gate-Source Voltage

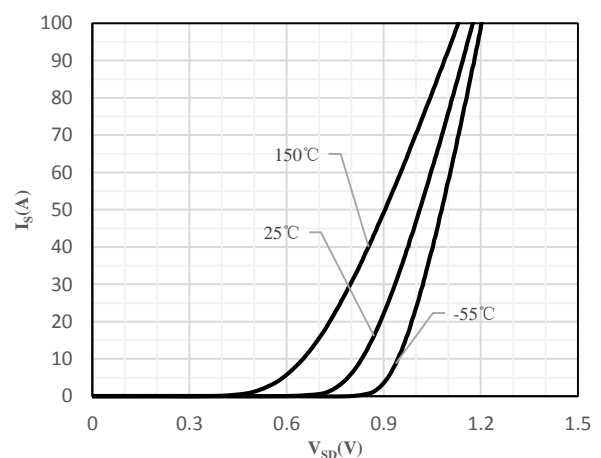

Fig 6 Body-Diode Characteristics

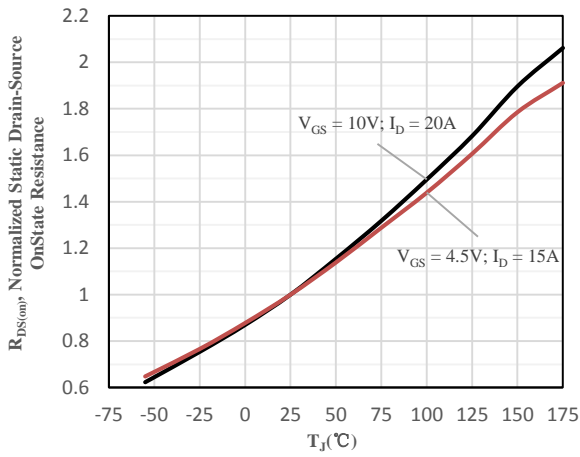

Fig 7 Normalized On-Resistance vs. Junction Temperature

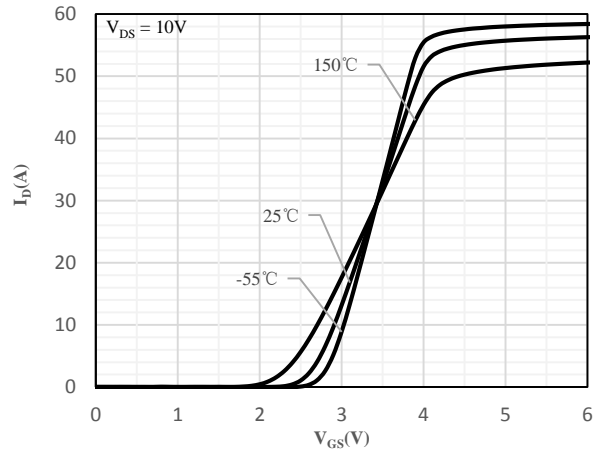

Fig 8 Transfer Characteristics

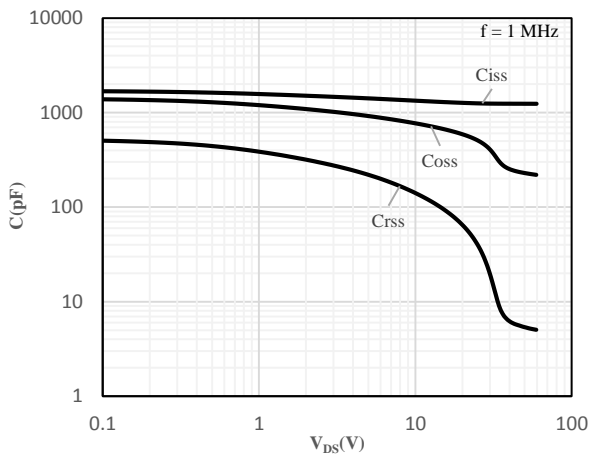

Fig 9 Capacitance Characteristics

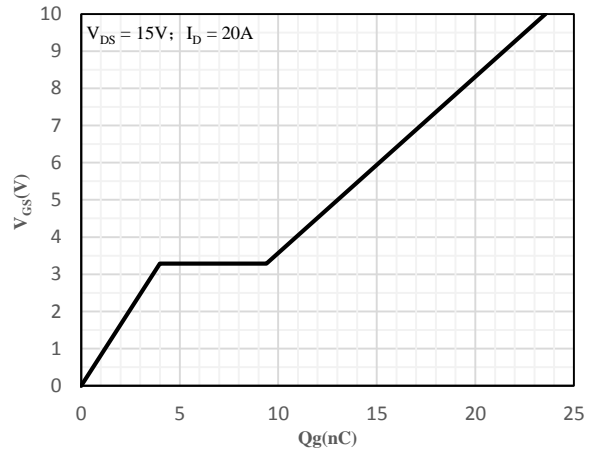

Fig 10 Gate-Charge Characteristics

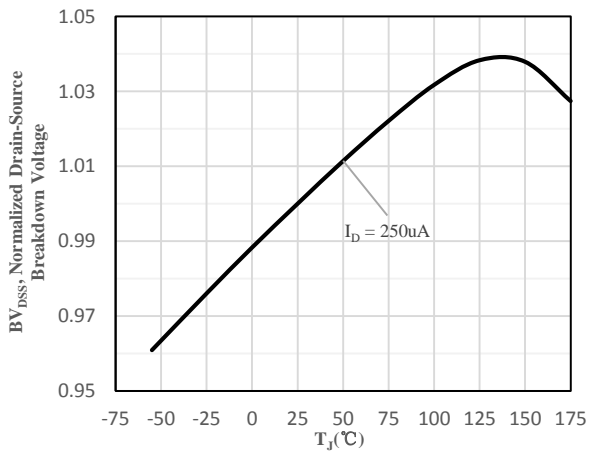

Fig 11 Normalized Breakdown Voltage vs. Junction Temperature

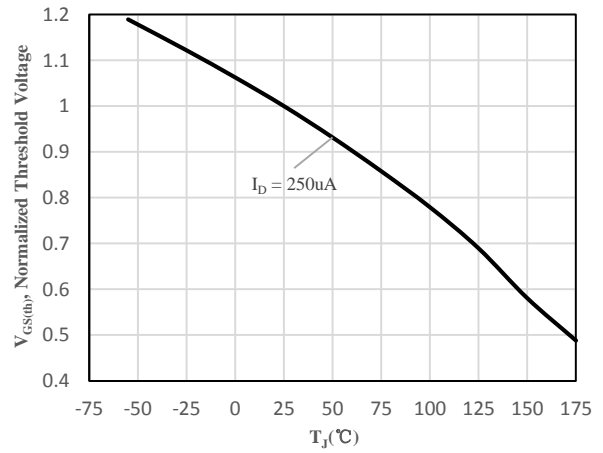
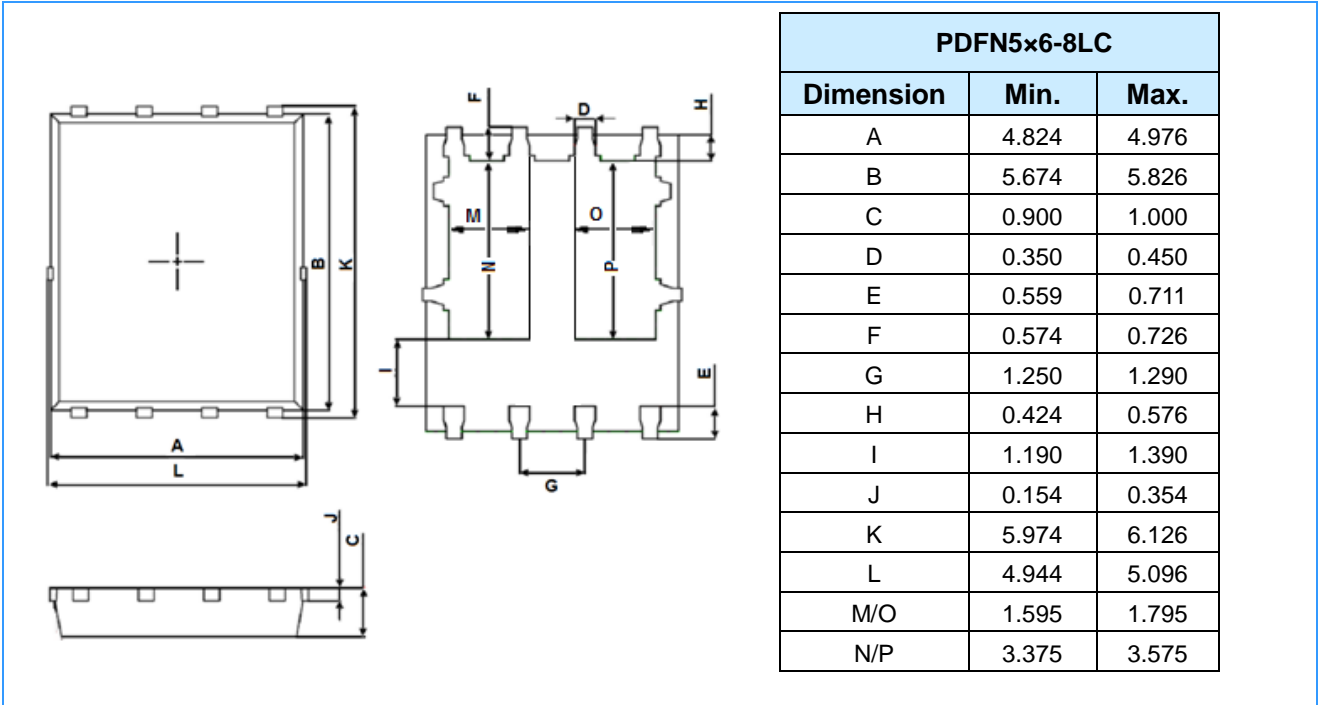

Fig 12 Normalized $V_{GS(th)}$ vs. Junction Temperature

Package Outline Dimensions (Unit: mm)



Mounting Pad Layout (Unit: mm)

