

### Features

- Excellent  $R_{DS(ON)}$  and low gate charge

**HF**

### Mechanical Data

- Case: PDFN3x3-8LC
- Molding Compound: UL Flammability Classification Rating 94V-0
- Terminals: Matte tin-plated leads; solderability-per MIL-STD-202, Method 208

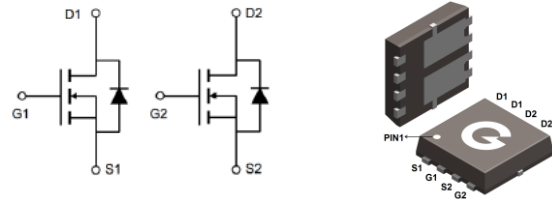

**PDFN3x3-8LC**

### Ordering Information

Part Number	Package	Shipping Quantity	Marking Code
GBLN4405-3DL8	PDFN3x3-8LC	5000 pcs / Tape & Reel	GBLN4405

### Maximum Ratings (@ $T_C = 25^\circ\text{C}$ unless otherwise specified)

Parameter	Symbol	Value	Unit
Drain-to-Source Voltage	$V_{DSS}$	40	V
Gate-to-Source Voltage	$V_{GSS}$	$\pm 20$	V
Continuous Drain Current ( $T_C = 25^\circ\text{C}$ )	$I_D$	22	A
Continuous Drain Current ( $T_C = 100^\circ\text{C}$ )		14	A
Pulsed Drain Current ( $t_p = 10\mu\text{s}$ , $T_C = 25^\circ\text{C}$ )	$I_{DM}$	88	A
Single Pulse Avalanche Energy <sup>*3</sup>	$E_{AS}$	9	mJ
Power Dissipation ( $T_C = 25^\circ\text{C}$ )	$P_D$	23	W
Operating Junction Temperature Range	$T_J$	-55 ~ +150	$^\circ\text{C}$
Storage Temperature Range	$T_{STG}$	-55 ~ +150	$^\circ\text{C}$

### Thermal Characteristics

Parameter	Symbol	Min.	Typ.	Max.	Unit
Thermal Resistance Junction-to-Case	$R_{\theta JC}$	-	5	5.5	$^\circ\text{C/W}$
Thermal Resistance Junction-to-Air <sup>*1</sup>	$R_{\theta JA}$	-	52	61	$^\circ\text{C/W}$

### Electrical Characteristics (@ T<sub>A</sub> = 25°C unless otherwise specified)

Symbol	Parameter	Test Condition	Min.	Typ.	Max.	Unit
<b>Static Characteristics</b>						
V <sub>DSS</sub>	Drain-Source Breakdown Voltage	V <sub>GS</sub> = 0V, I <sub>D</sub> = 250μA	40	-	-	V
I <sub>DSS</sub>	Zero Gate Voltage Drain Current	V <sub>DS</sub> = 40V, V <sub>GS</sub> = 0V	-	-	1	μA
I <sub>GSS</sub>	Gate-Body Leakage Current	V <sub>GS</sub> = ±20V, V <sub>DS</sub> = 0V	-	-	±100	nA
<b>On Characteristics</b>						
R <sub>DS(ON)</sub>	Drain-Source On-resistance <sup>*2</sup>	V <sub>GS</sub> = 10V, I <sub>D</sub> = 4A	-	19	23	mΩ
		V <sub>GS</sub> = 4.5V, I <sub>D</sub> = 3A	-	25	30	mΩ
V <sub>GS(th)</sub>	Gate Threshold Voltage	V <sub>DS</sub> = V <sub>GS</sub> , I <sub>D</sub> = 250μA	1	1.5	2.5	V
R <sub>G</sub>	Gate Resistance	V <sub>GS</sub> = 0V, f = 1MHz	-	4.5	-	Ω
<b>Dynamic Characteristics</b>						
C <sub>ISS</sub>	Input Capacitance	V <sub>GS</sub> = 0V V <sub>DS</sub> = 20V f = 1.0MHz	-	732	-	pF
C <sub>OSS</sub>	Output Capacitance		-	59	-	
C <sub>RSS</sub>	Reverse Transfer Capacitance		-	46	-	
<b>Switching Characteristics</b>						
t <sub>d(ON)</sub>	Turn-on Delay Time <sup>*4</sup>	V <sub>DD</sub> = 20V, V <sub>GS</sub> = 10V R <sub>G</sub> = 3Ω, R <sub>L</sub> = 1 Ω I <sub>D</sub> = 8A	-	11	-	ns
t <sub>r</sub>	Turn-on Rise Time <sup>*4</sup>		-	13	-	
t <sub>d(OFF)</sub>	Turn-Off Delay Time <sup>*4</sup>		-	36	-	
t <sub>f</sub>	Turn-Off Fall Time <sup>*4</sup>		-	9	-	
Q <sub>G</sub>	Total Gate-Charge	V <sub>DD</sub> = 20V V <sub>GS</sub> = 10V I <sub>D</sub> = 5A	-	16.7	-	nC
Q <sub>GS</sub>	Gate to Source Charge		-	2.6	-	
Q <sub>GD</sub>	Gate to Drain (Miller) Charge		-	2.5	-	
<b>Source-Drain Diode Characteristics</b>						
V <sub>SD</sub>	Diode Forward Voltage <sup>*2</sup>	I <sub>SD</sub> = 8A, V <sub>GS</sub> = 0V	-	0.88	1.2	V
t <sub>rr</sub>	Reverse Recovery Time	I <sub>F</sub> = 8A, V <sub>GS</sub> = 0V di/dt = 100A/μs	-	17	-	ns
Q <sub>rr</sub>	Reverse Recovery Charge		-	6.2	-	nC

Notes:

1. The data tested by surface mounted on a 1 inch<sup>2</sup> FR-4 board with 2OZ copper
2. The data tested by pulsed, pulse width ≤ 300μs, duty cycle ≤ 2%
3. The E<sub>AS</sub> data shows Max. rating. The test condition is V<sub>DD</sub> = 20V, V<sub>GS</sub> = 10V, L = 0.5mH
4. Guaranteed by design, not subject to production

Ratings and Characteristics Curves (@  $T_A = 25^\circ\text{C}$  unless otherwise specified)

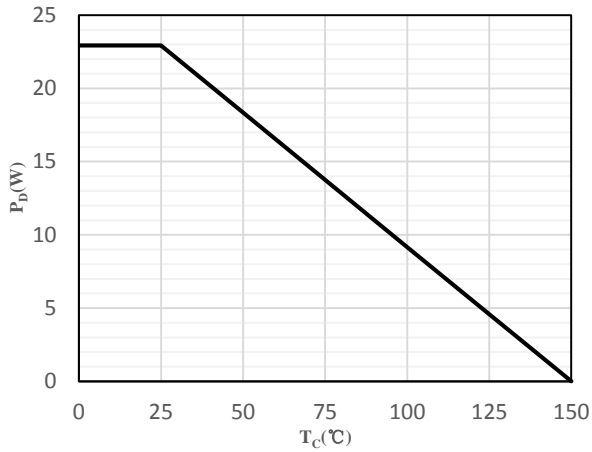

Fig 1 Power Dissipation

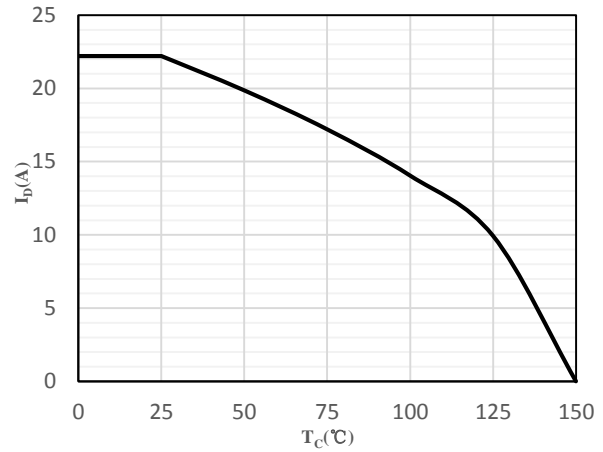

Fig 2 Drain Current

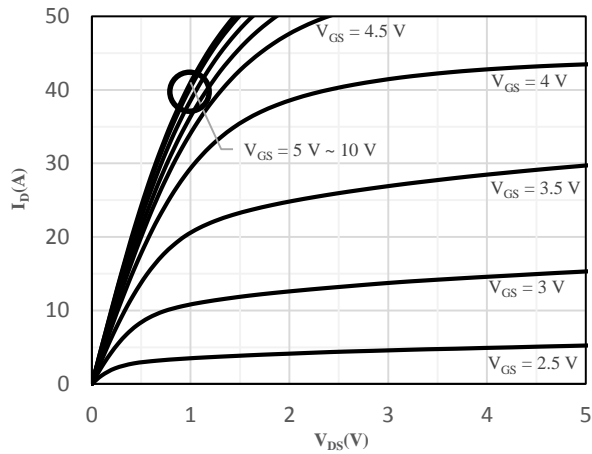

Fig 3 Typical Output Characteristics

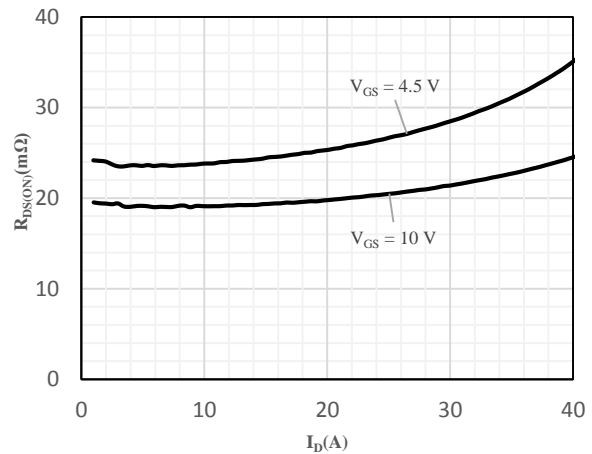

Fig 4 On-Resistance vs. Drain Current and Gate Voltage

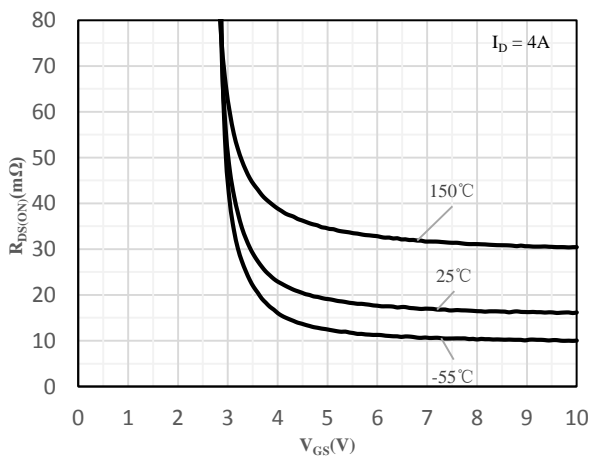

Fig 5 On-Resistance vs. Gate-Source Voltage

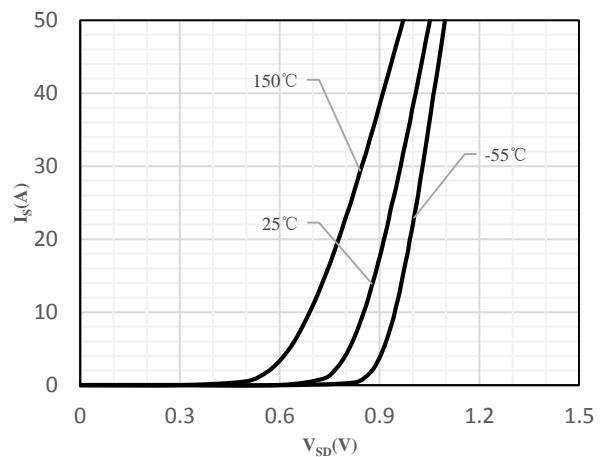

Fig 6 Body-Diode Characteristics

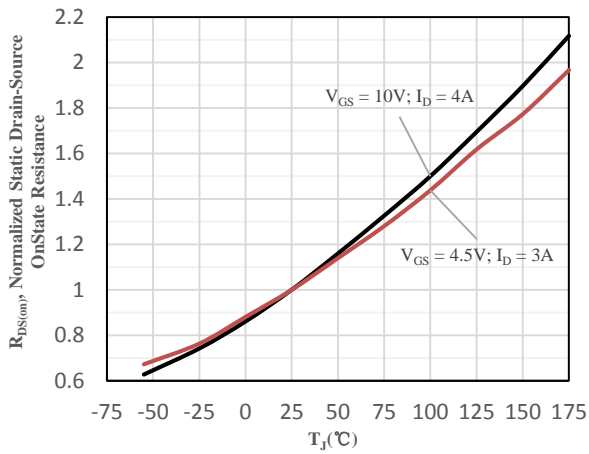

Fig 7 Normalized On-Resistance vs. Junction Temperature

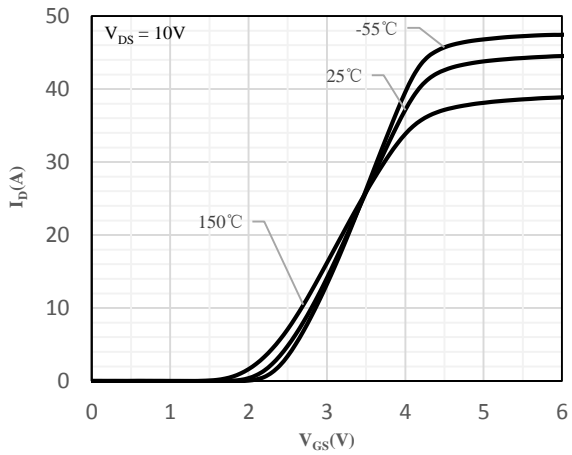

Fig 8 Transfer Characteristics

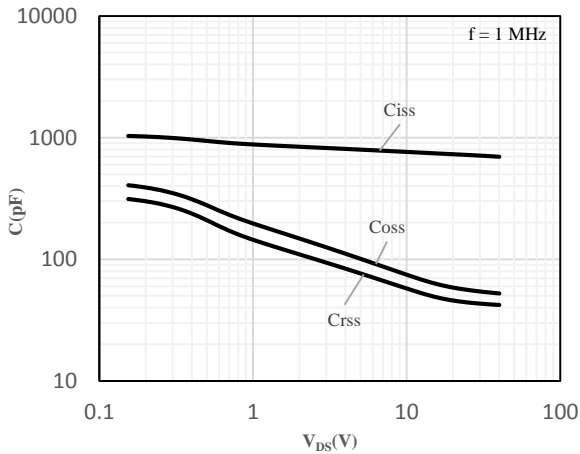

Fig 9 Capacitance Characteristics

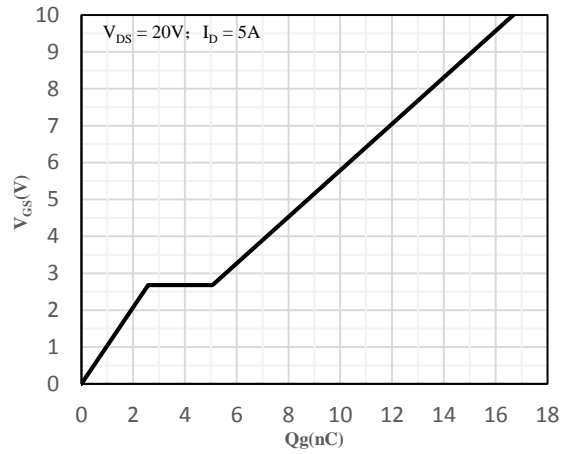

Fig 10 Gate-Charge Characteristics

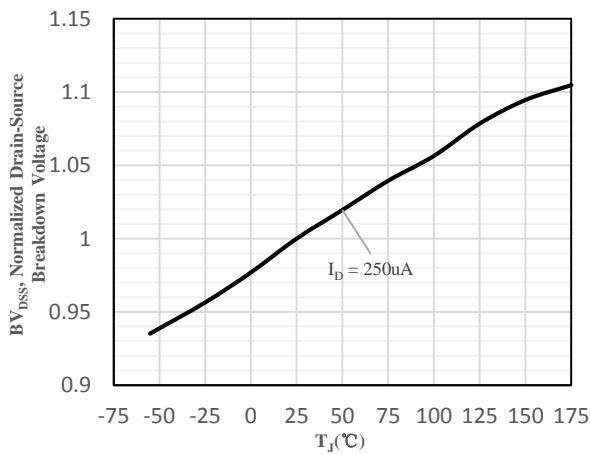

Fig 11 Normalized Breakdown Voltage vs. Junction Temperature

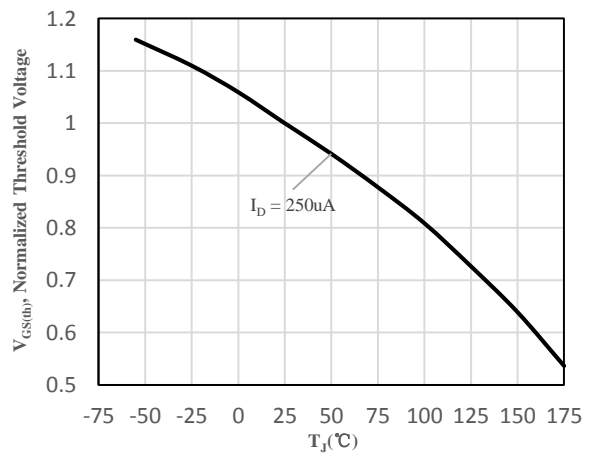

Fig 12 Normalized  $V_{GS(th)}$  vs. Junction Temperature

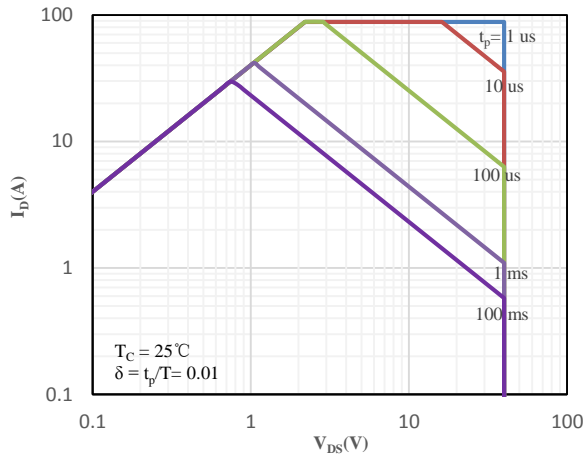

Fig 13 Safe Operation Area

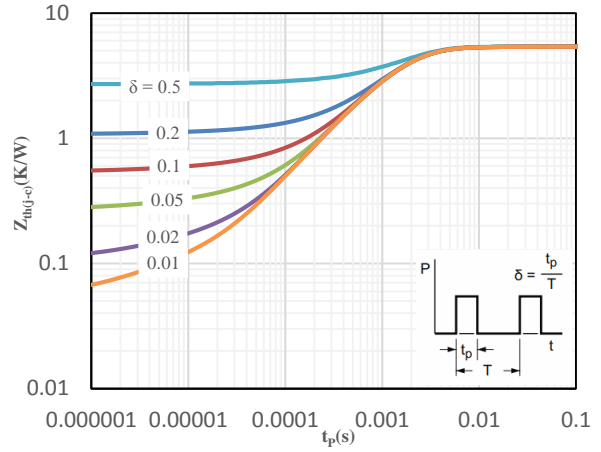
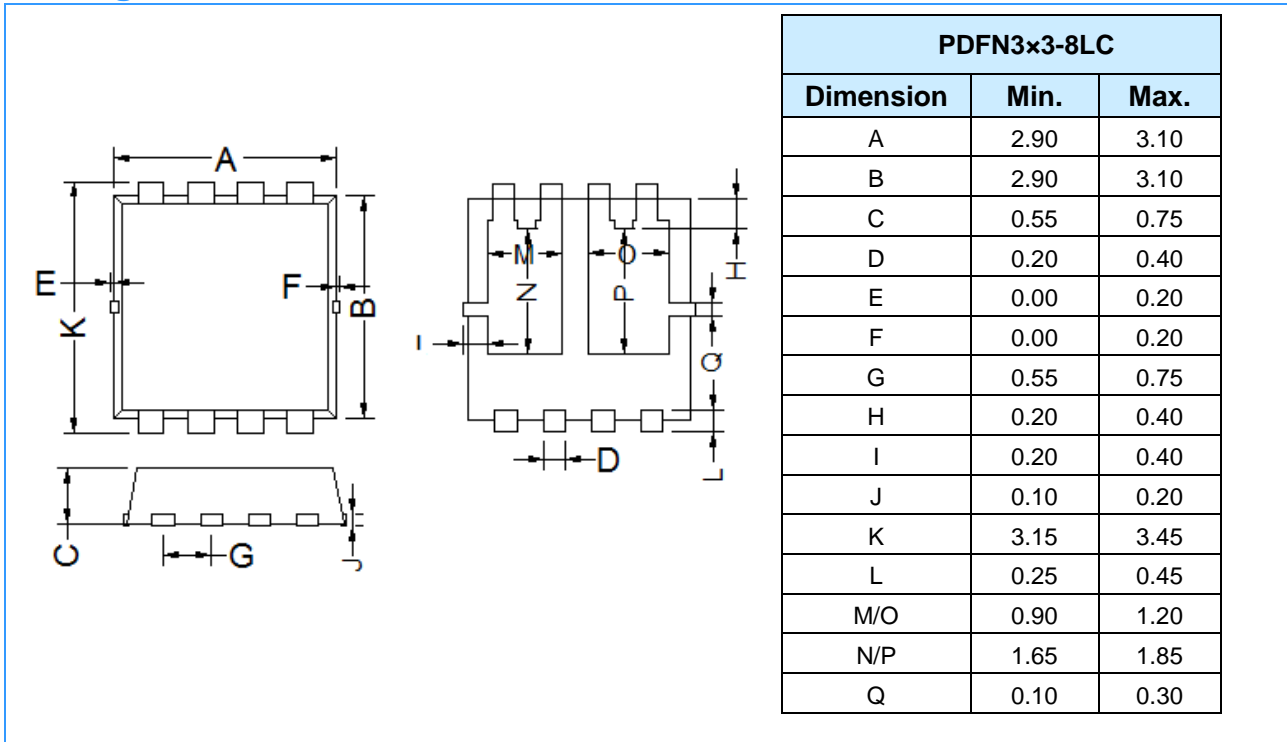
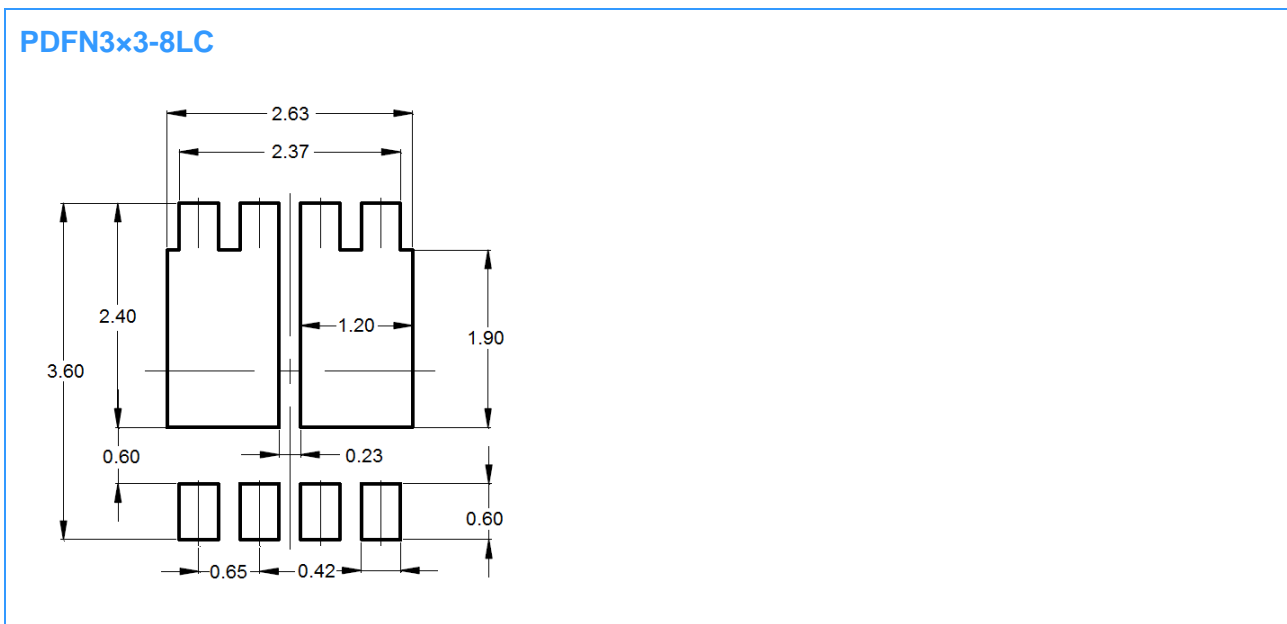

Fig 14 Maximum transient thermal impedance

### Package Outline Dimensions (Unit: mm)



### Mounting Pad Layout (Unit: mm)



### IMPORTANT NOTICE

Changzhou Galaxy Century Microelectronics (GME) reserves the right to make changes without further notice to any product information (copyrighted) herein to make corrections, modifications, improvements, or other changes. GME does not assume any liability arising out of the application or use of any product described herein; neither does it convey any license under its patent rights, nor the rights of others.