

Features

- Low input capacitance
- Low gate charge
- Fast switching speed
- RoHS compliant with Halogen-free

Applications

- Synchronous Rectification
- Motor Control
- Portable equipment application

Mechanical Data

- Case: PDFN3x3-8LC
- Molding Compound: UL Flammability Classification Rating 94V-0
- Terminals: Matte tin-plated leads; solderability-per MIL-STD-202, Method 208

HF

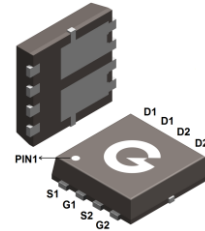
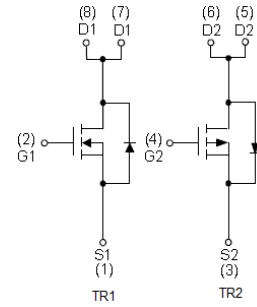

PDFN3x3-8LC

Ordering Information

Part Number	Package	Shipping Quantity	Marking Code
GBLH6602-3DL8	PDFN3x3-8LC	5000 pcs / Tape & Reel	GBLH6602

Maximum Ratings (@ T_C = 25°C unless otherwise specified)

Parameter	Symbol	N	P	Unit
Drain-to-Source Voltage	V _{DSS}	60	-60	V
Gate-to-Source Voltage	V _{GSS}	±20	±20	V
Continuous Drain Current (T _C = 25°C)	I _D	9.2	-6.4	A
Continuous Drain Current (T _C = 100°C)		5.8	-4	A
Continuous Drain Current (T _A = 25°C) *1		3	-2.1	A
Continuous Drain Current (T _A = 100°C) *1		1.9	-1.3	A
Pulsed Drain Current (t _p = 10μs, T _A = 25°C)	I _{DM}	40	-30	A
Single Pulse Avalanche Energy *3	E _{AS}	10	10	mJ
Power Dissipation (T _C = 25°C)	P _D	14		W
Power Dissipation (T _A = 25°C) *1		1.5		W
Operating Junction Temperature Range	T _J	-55 ~ +150		°C
Storage Temperature Range	T _{STG}	-55 ~ +150		°C

Thermal Characteristics

Parameter	Symbol	Min.	Typ.	Max.	Unit
Thermal Resistance Junction-to-Case	R _{θJC}	-	-	9	°C/W
Thermal Resistance Junction-to-Air *1	R _{θJA}	-	-	83	°C/W

Electrical Characteristics-N (@ T_A = 25°C unless otherwise specified)

Symbol	Parameter	Test Condition	Min.	Typ.	Max.	Unit
Static Characteristics						
V _{DSS}	Drain-Source Breakdown Voltage	V _{GS} = 0V, I _D = 250μA	60	-	-	V
I _{DSS}	Zero Gate Voltage Drain Current	V _{DS} = 60V, V _{GS} = 0V	-	-	1	μA
I _{GSS}	Gate-Body Leakage Current	V _{GS} = ±20V, V _{DS} = 0V	-	-	±100	nA
On Characteristics						
R _{DS(ON)}	Drain-Source On-resistance ^{*2}	V _{GS} = 10V, I _D = 3A	-	60	80	mΩ
		V _{GS} = 4.5V, I _D = 2A	-	70	100	mΩ
V _{GS(th)}	Gate Threshold Voltage	V _{DS} = V _{GS} , I _D = 250μA	1	1.4	2.5	V
R _G	Gate Resistance	V _{GS} = 0V, f = 1MHz	-	3	-	Ω
Dynamic Characteristics						
C _{ISS}	Input Capacitance	V _{GS} = 0V V _{DS} = 30V f = 1.0MHz	-	517	-	pF
C _{OSS}	Output Capacitance		-	28	-	
C _{RSS}	Reverse Transfer Capacitance		-	22	-	
Switching Characteristics						
t _{d(ON)}	Turn-on Delay Time ^{*4}	V _{DD} = 30V V _{GS} = 10V I _D = 3A R _G = 3Ω	-	4	-	ns
t _r	Turn-on Rise Time ^{*4}		-	2	-	
t _{d(OFF)}	Turn-Off Delay Time ^{*4}		-	13.3	-	
t _f	Turn-Off Fall Time ^{*4}		-	1.6	-	
Q _G	Total Gate-Charge	V _{DD} = 30V V _{GS} = 10V I _D = 3A	-	15	-	nC
Q _{GS}	Gate to Source Charge		-	2.2	-	
Q _{GD}	Gate to Drain (Miller) Charge		-	2.6	-	
Source-Drain Diode Characteristics						
V _{SD}	Diode Forward Voltage ^{*2}	I _{SD} = 3A, V _{GS} = 0V	-	0.8	1.2	V
t _{rr}	Reverse Recovery Time	I _{SD} = 3A, V _{GS} = 0V di/dt = 100A/μs	-	20	-	ns
Q _{rr}	Reverse Recovery Charge		-	15	-	nC

Electrical Characteristics-P (@ T_A = 25°C unless otherwise specified)

Symbol	Parameter	Test Condition	Min.	Typ.	Max.	Unit
Static Characteristics						
V _{DSS}	Drain-Source Breakdown Voltage	V _{GS} = 0V, I _D = -250μA	-60	-	-	V
I _{DSS}	Zero Gate Voltage Drain Current	V _{DS} = -60V, V _{GS} = 0V	-	-	-1	μA
I _{GSS}	Gate-Body Leakage Current	V _{GS} = ±20V, V _{DS} = 0V	-	-	±100	nA
On Characteristics						
R _{DS(ON)}	Drain-Source On-resistance ^{*2}	V _{GS} = -10V, I _D = -3A	-	150	180	mΩ
		V _{GS} = -4.5V, I _D = -2A	-	186	250	mΩ
V _{GS(th)}	Gate Threshold Voltage	V _{DS} = V _{GS} , I _D = -250μA	-1	-1.6	-2.5	V
R _G	Gate Resistance	V _{GS} = 0V, f = 1MHz	-	20	-	Ω
Dynamic Characteristics						
C _{ISS}	Input Capacitance	V _{GS} = 0V V _{DS} = -30V f = 1.0MHz	-	403	-	pF
C _{OSS}	Output Capacitance		-	25	-	
C _{RSS}	Reverse Transfer Capacitance		-	18	-	
Switching Characteristics						
t _{d(ON)}	Turn-on Delay Time ^{*4}	V _{DS} = -15V V _{GS} = -10V I _D = -1A R _G = 3.3Ω	-	17.4	-	ns
t _r	Turn-on Rise Time ^{*4}		-	5.4	-	
t _{d(OFF)}	Turn-Off Delay Time ^{*4}		-	37.2	-	
t _f	Turn-Off Fall Time ^{*4}		-	2.4	-	
Q _G	Total Gate-Charge	V _{DS} = -30V V _{GS} = -10V I _D = -3A	-	11	-	nC
Q _{GS}	Gate to Source Charge		-	2	-	
Q _{GD}	Gate to Drain (Miller) Charge		-	1.6	-	
Source-Drain Diode Characteristics						
V _{SD}	Diode Forward Voltage ^{*2}	I _{SD} = -3A, V _{GS} = 0V	-	-0.9	-1.2	V
t _{rr}	Reverse Recovery Time	I _{SD} = -3A, V _{GS} = 0V di/dt = 100A/μs	-	16	-	ns
Q _{rr}	Reverse Recovery Charge		-	8	-	nC

Notes:

- The data tested by surface mounted on a 1 inch² FR-4 board with 2OZ copper
- The data tested by pulsed, pulse width ≤ 300μs, duty cycle ≤ 2%
- The E_{AS} data shows Max. rating. The test condition is N: V_{DD} = 30V, V_{GS} = 10V, L = 0.5mH
P: V_{DD} = -30V, V_{GS} = -10V, L = 0.5mH
- Guaranteed by design, not subject to production

Ratings and Characteristics Curves-N (@ $T_A = 25^\circ\text{C}$ unless otherwise specified)

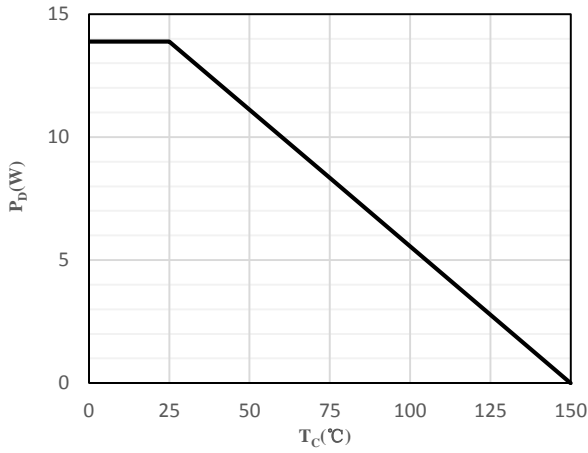

Fig 1 Power Dissipation

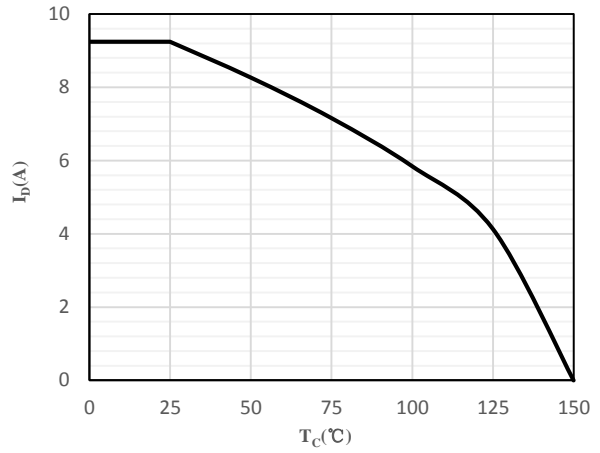

Fig 2 Drain Current

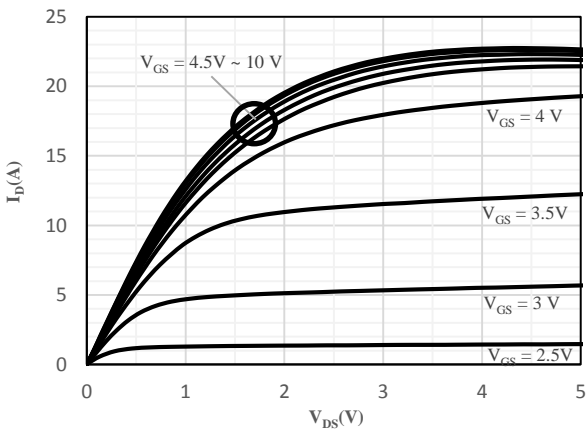

Fig 3 Typical Output Characteristics

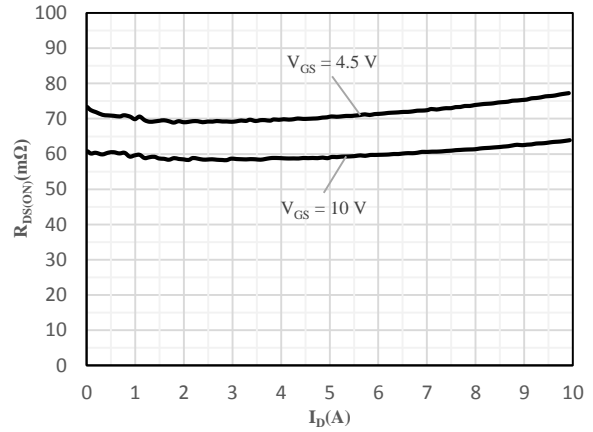

Fig 4 On-Resistance vs. Drain Current and Gate Voltage

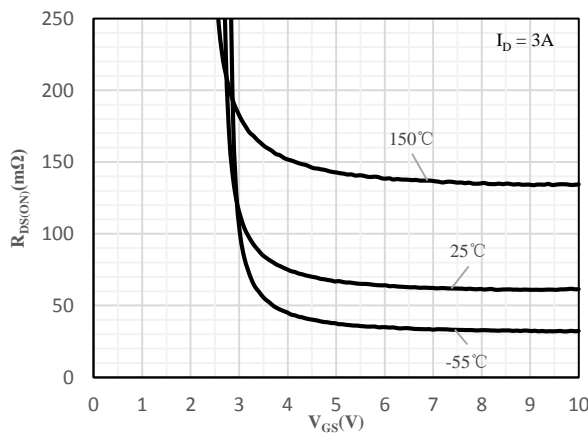

Fig 5 On-Resistance vs. Gate-Source Voltage

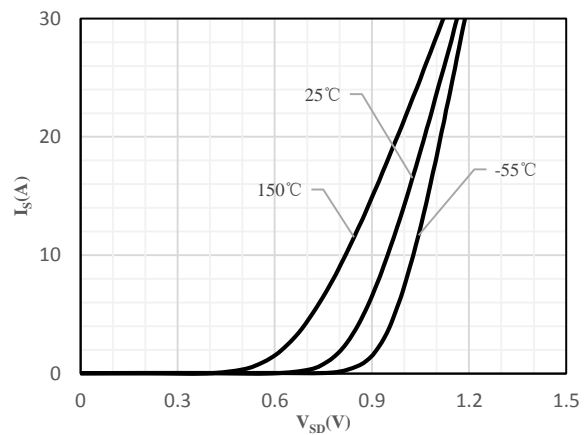

Fig 6 Body-Diode Characteristics

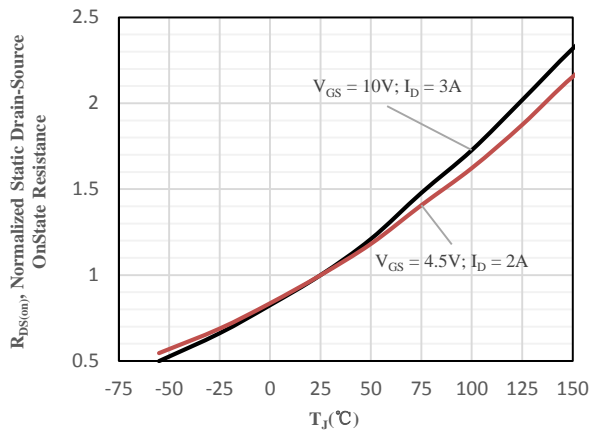

Fig 7 Normalized On-Resistance vs. Junction Temperature

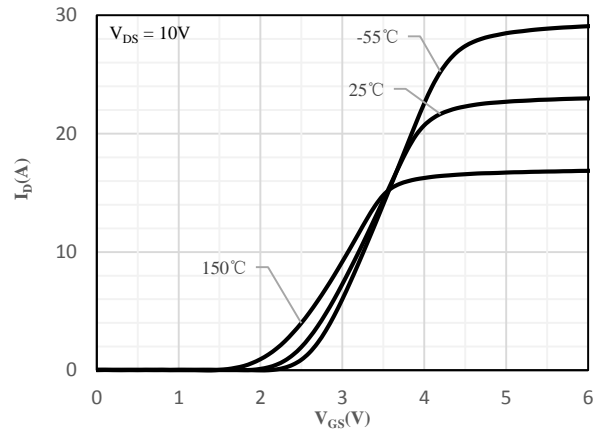

Fig 8 Transfer Characteristics

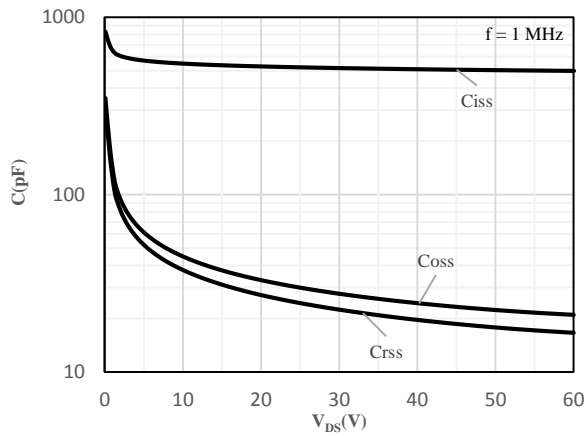

Fig 9 Capacitance Characteristics

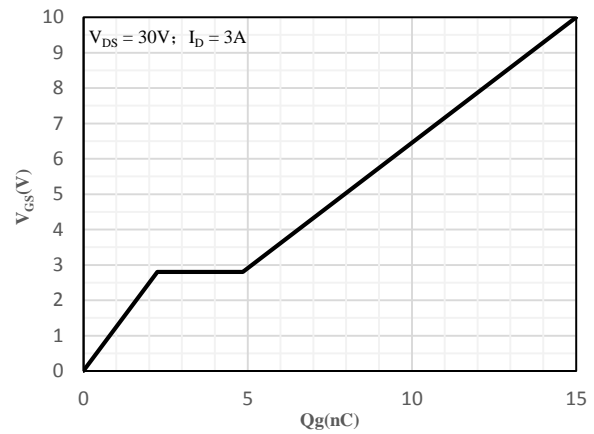

Fig 10 Gate-Charge Characteristics

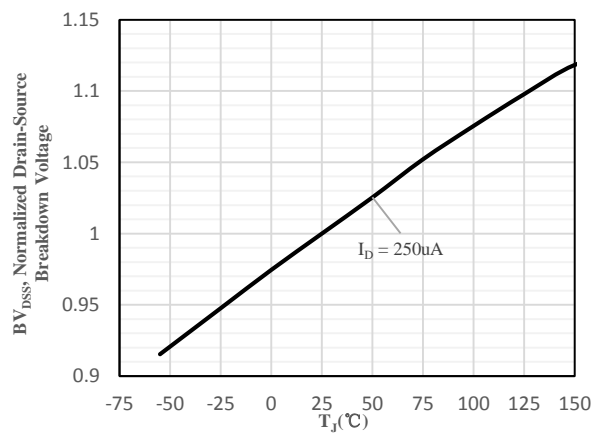

Fig 11 Normalized Breakdown Voltage vs. Junction Temperature

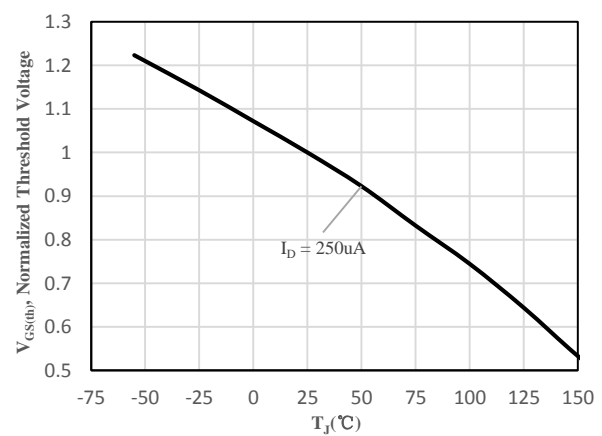

Fig 12 Normalized $V_{GS(th)}$ vs. Junction Temperature

Ratings and Characteristics Curves-P (@ $T_A = 25^\circ\text{C}$ unless otherwise specified)

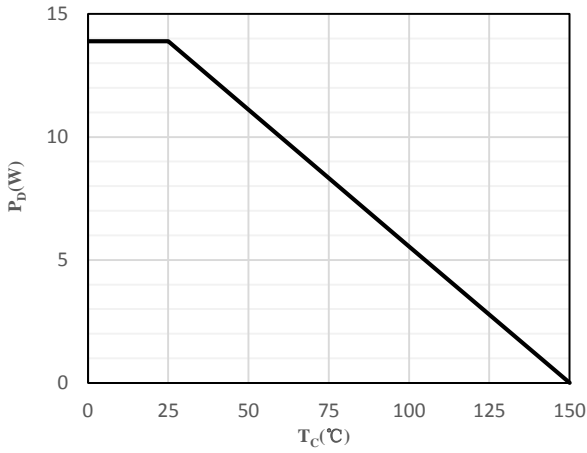

Fig 1 Power Dissipation

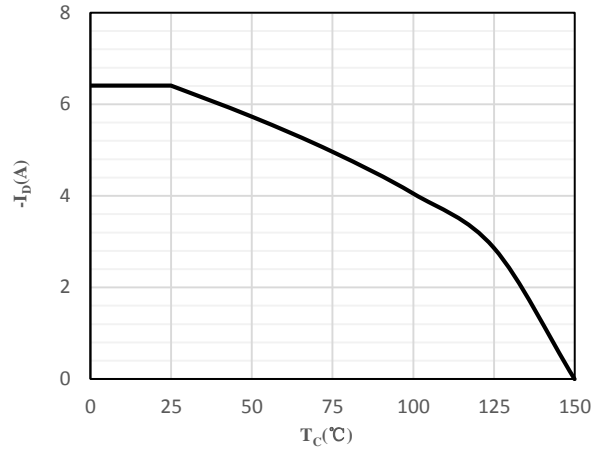

Fig 2 Drain Current

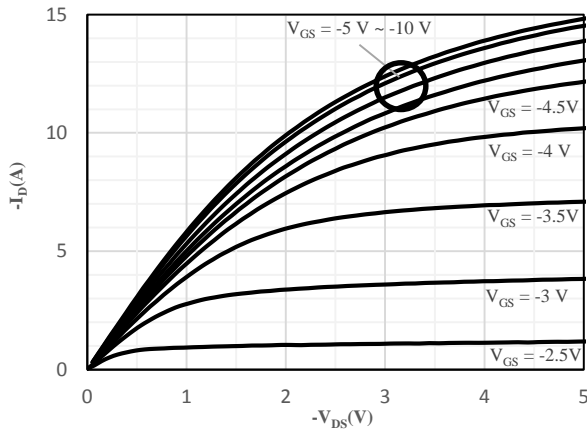

Fig 3 Typical Output Characteristics

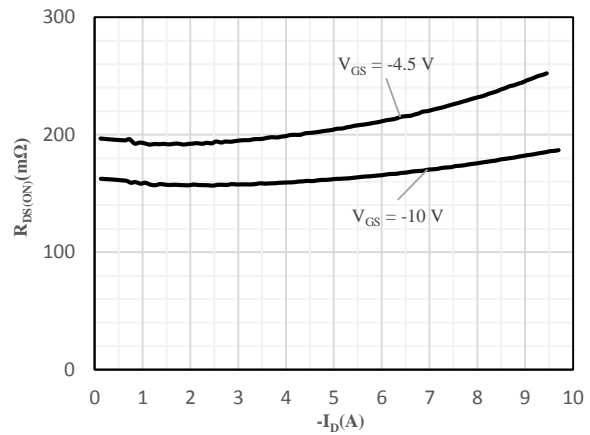

Fig 4 On-Resistance vs. Drain Current and Gate Voltage

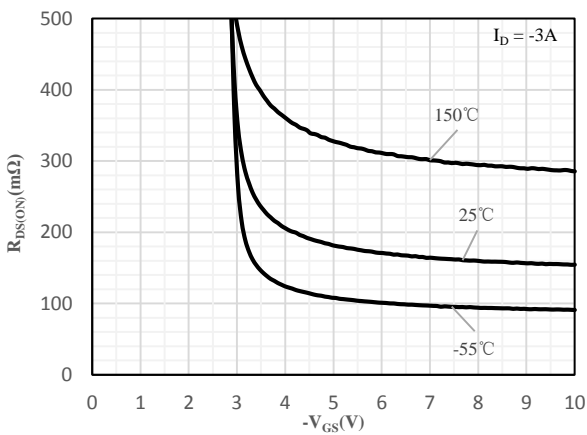

Fig 5 On-Resistance vs. Gate-Source Voltage

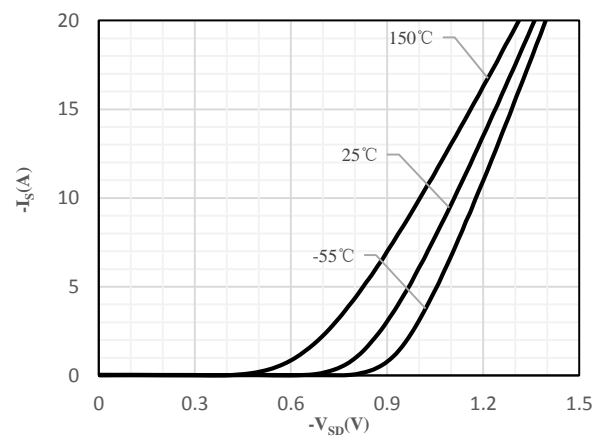

Fig 6 Body-Diode Characteristics

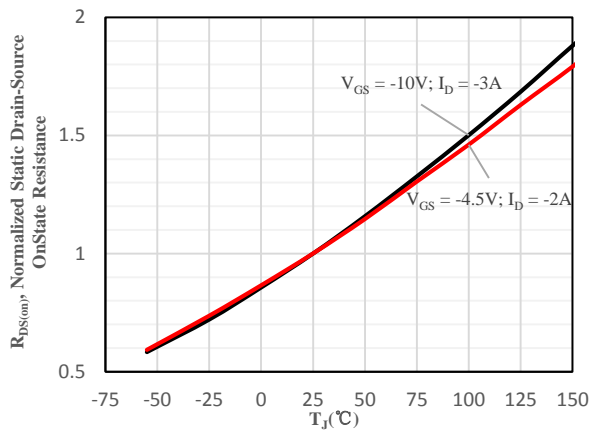

Fig 7 Normalized On-Resistance vs. Junction Temperature

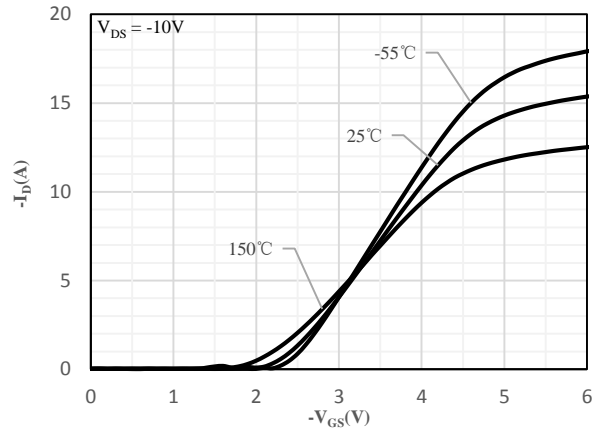

Fig 8 Transfer Characteristics

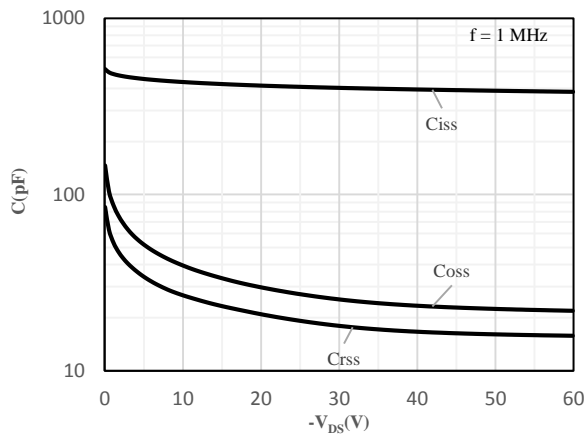

Fig 9 Capacitance Characteristics

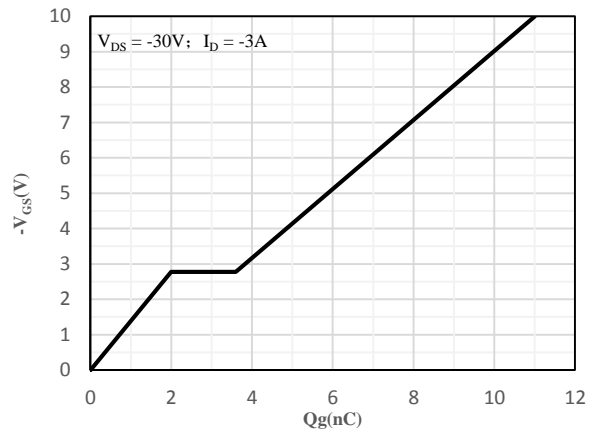

Fig 10 Gate-Charge Characteristics

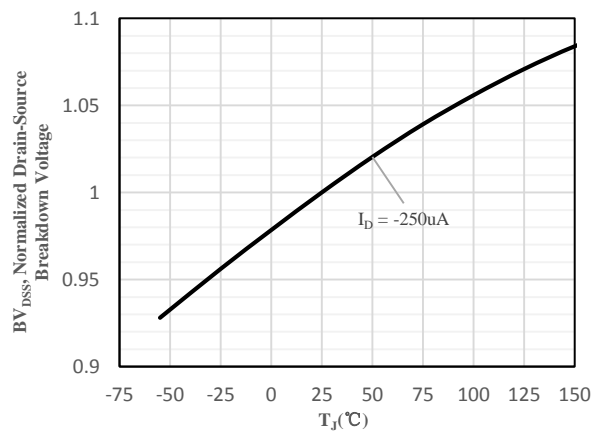

Fig 11 Normalized Breakdown Voltage vs. Junction Temperature

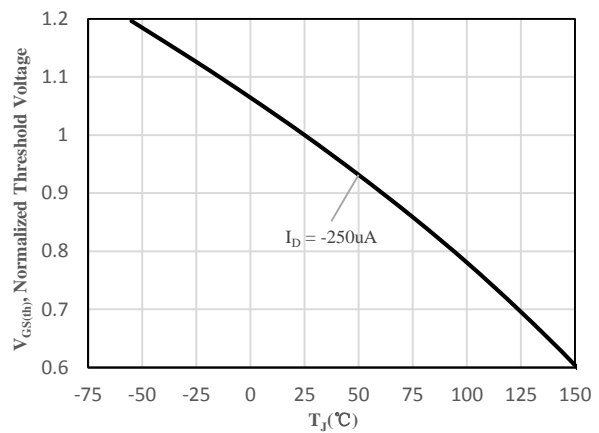
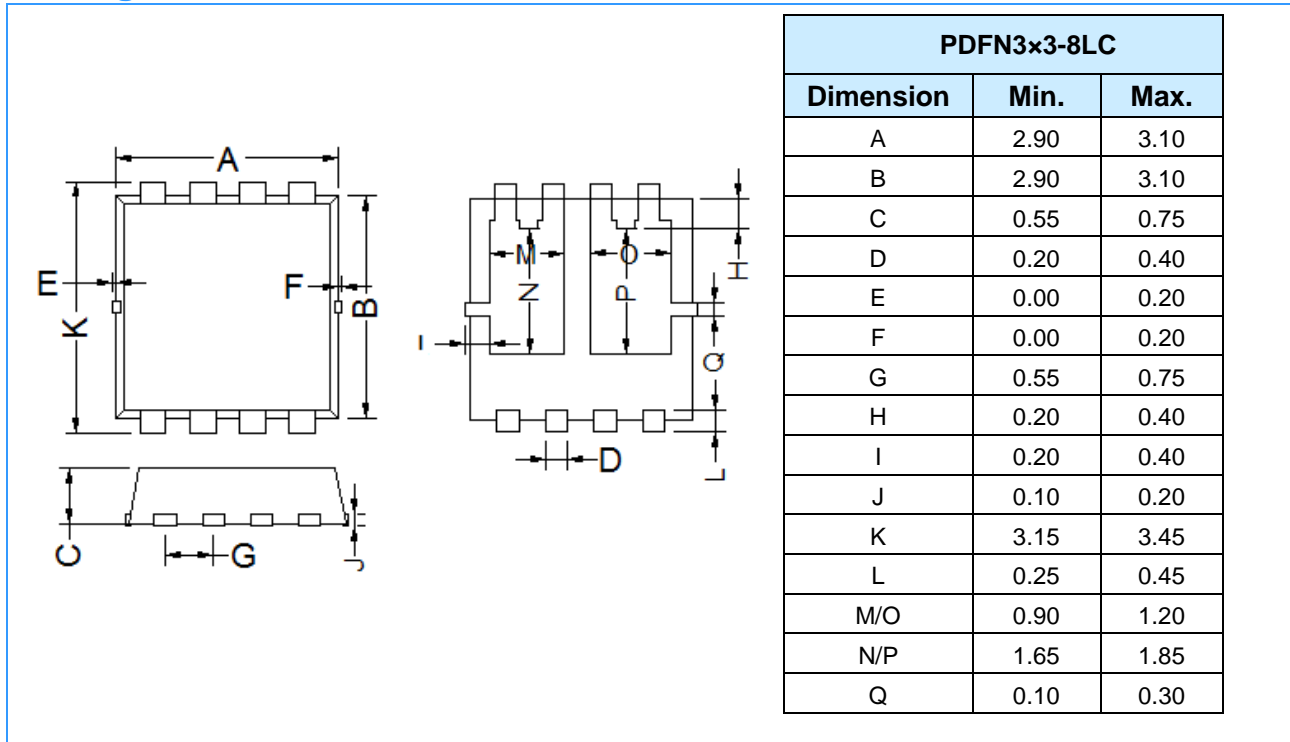

Fig 12 Normalized $V_{GS(th)}$ vs. Junction Temperature

Package Outline Dimensions (Unit: mm)



Mounting Pad Layout (Unit: mm)

