

### Features

- Excellent  $R_{DS(ON)}$
- Low gate charge
- RoHS compliant with Halogen-free

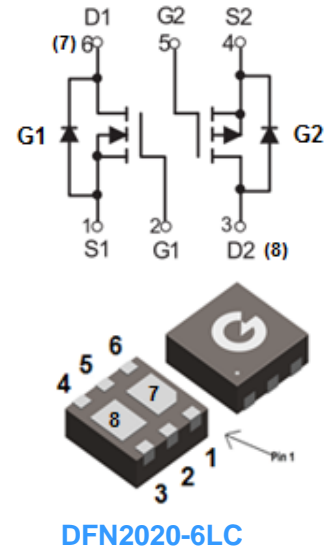
HF

### Applications

- Load Switch
- PWM Application

### Mechanical Data

- Case: DFN2020-6LC
- Molding Compound: UL Flammability Classification Rating 94V-0
- Terminals: Matte tin-plated leads; solderability-per MIL-STD-202, Method 208



## Ordering Information

Part Number	Package	Shipping Quantity	Marking Code
GBLH2201DF2	DFN2020-6LC	3000 pcs / Tape & Reel	H2201

## Maximum Ratings (@ $T_A = 25^\circ\text{C}$ unless otherwise specified)

Parameter	Symbol	G <sub>1</sub>	G <sub>2</sub>	Unit
Drain-to-Source Voltage	$V_{DSS}$	20	-20	V
Gate-to-Source Voltage	$V_{GSS}$	$\pm 12$	$\pm 12$	V
Continuous Drain Current ( $T_A = 25^\circ\text{C}$ )	$I_D$	3	-3	A
Continuous Drain Current ( $T_A = 100^\circ\text{C}$ )	$I_D$	2	-2	A
Pulsed Drain Current *1	$I_{DM}$	12	-12	A

## Thermal Characteristics

Parameter	Symbol	G <sub>1</sub>	G <sub>2</sub>	Unit
Power Dissipation ( $T_A = 25^\circ\text{C}$ )	$P_D$	0.77	1	W
Thermal Resistance Junction-to-Air	$R_{\theta JA}$	162	125	$^\circ\text{C}/\text{W}$
Operating Junction Temperature Range	$T_J$	-55 ~ +150		$^\circ\text{C}$
Storage Temperature Range	$T_{STG}$	-55 ~ +150		$^\circ\text{C}$

### Electrical Characteristics-NMOS $G_1$ (@ $T_J = 25^\circ\text{C}$ unless otherwise specified)

Symbol	Parameter	Test Condition	Min.	Typ.	Max.	Unit
<b>Static Characteristics</b>						
$V_{DSS}$	Drain-Source Breakdown Voltage	$V_{GS} = 0V, I_D = 250\mu A$	20	-	-	V
$I_{DSS}$	Zero Gate Voltage Drain Current	$V_{DS} = 20V, V_{GS} = 0V$	-	-	1	$\mu A$
$I_{GSS}$	Gate-Body Leakage Current	$V_{GS} = \pm 12V, V_{DS} = 0V$	-	-	$\pm 100$	nA
<b>On Characteristics</b>						
$R_{DS(ON)}$	Static Drain-Source On-resistance <sup>*2</sup>	$V_{GS} = 4.5V, I_D = 3A$	-	-	55	m $\Omega$
		$V_{GS} = 2.5V, I_D = 2A$	-	-	85	m $\Omega$
$V_{GS(th)}$	Gate Threshold Voltage	$V_{DS} = V_{GS}, I_D = 250\mu A$	0.4	-	1.0	V
<b>Dynamic Characteristics</b>						
$C_{ISS}$	Input Capacitance	$V_{GS} = 0V$ $V_{DS} = 10V$ $f = 1.0MHz$	-	184	-	pF
$C_{OSS}$	Output Capacitance		-	38	-	
$C_{RSS}$	Reverse Transfer Capacitance		-	28	-	
<b>Switching Characteristics</b>						
$t_{d(ON)}$	Turn-on Delay Time	$V_{GS} = 4.5V$ $V_{DD} = 10V$ $R_G = 3\Omega$ $I_D = 3A$	-	2.3	-	ns
$t_r$	Turn-on Rise Time		-	3.1	-	
$t_{d(OFF)}$	Turn-Off Delay Time		-	9.2	-	
$t_f$	Turn-Off Fall Time		-	2.5	-	
$Q_G$	Total Gate-Charge	$V_{DD} = 10V$ $V_{GS} = 4.5V$ $I_D = 3A$	-	2.7	-	nC
$Q_{GS}$	Gate to Source Charge		-	0.4	-	
$Q_{GD}$	Gate to Drain (Miller) Charge		-	0.5	-	
<b>Source-Drain Diode Characteristics</b>						
$V_{SD}$	Diode Forward Voltage	$I_{SD} = 3A, V_{GS} = 0V$	-	-	1.2	V

Notes:

- 1、 Repetitive rating; pulse width limited by maximum junction temperature
- 2、 The data tested by pulsed, pulse width  $\leq 300\mu s$ , duty cycle  $\leq 0.5\%$

### Electrical Characteristics-PMOS G<sub>2</sub> (@ T<sub>A</sub> = 25°C unless otherwise specified)

Symbol	Parameter	Test Condition	Min.	Typ.	Max.	Unit
<b>Static Characteristics</b>						
V <sub>DSS</sub>	Drain-Source Breakdown Voltage	V <sub>GS</sub> = 0V, I <sub>D</sub> = -250μA	-20	-	-	V
I <sub>DSS</sub>	Zero Gate Voltage Drain Current	V <sub>DS</sub> = -20V, V <sub>GS</sub> = 0V	-	-	-1	μA
I <sub>GSS</sub>	Gate-Body Leakage Current	V <sub>GS</sub> = ±12V, V <sub>DS</sub> = 0V	-	-	±100	nA
<b>On Characteristics</b>						
R <sub>DS(ON)</sub>	Static Drain-Source On-resistance <sup>*2</sup>	V <sub>GS</sub> = -4.5V, I <sub>D</sub> = -3A	-	-	70	mΩ
		V <sub>GS</sub> = -2.5V, I <sub>D</sub> = -2A	-	-	100	mΩ
V <sub>GS(th)</sub>	Gate Threshold Voltage	V <sub>DS</sub> = V <sub>GS</sub> , I <sub>D</sub> = -250μA	-0.5	-	-1.0	V
<b>Dynamic Characteristics</b>						
C <sub>ISS</sub>	Input Capacitance	V <sub>GS</sub> = 0V V <sub>DS</sub> = -10V f = 1.0MHz	-	503	-	pF
C <sub>OSS</sub>	Output Capacitance					
C <sub>RSS</sub>	Reverse Transfer Capacitance					
<b>Switching Characteristics</b>						
t <sub>d(ON)</sub>	Turn-on Delay Time	V <sub>GS</sub> = -4.5V, V <sub>DD</sub> = -10V R <sub>G</sub> = 1Ω, R <sub>L</sub> = 1.2Ω I <sub>D</sub> = -3A	-	11	-	ns
t <sub>r</sub>	Turn-on Rise Time					
t <sub>d(OFF)</sub>	Turn-Off Delay Time					
t <sub>f</sub>	Turn-Off Fall Time					
Q <sub>G</sub>	Total Gate-Charge	V <sub>GS</sub> = -4.5V V <sub>DD</sub> = -10V I <sub>D</sub> = -2A	-	4.1	-	nC
Q <sub>GS</sub>	Gate to Source Charge					
Q <sub>GD</sub>	Gate to Drain (Miller) Charge					
<b>Source-Drain Diode Characteristics</b>						
V <sub>SD</sub>	Diode Forward Voltage <sup>*2</sup>	I <sub>SD</sub> = -4.1A, V <sub>GS</sub> = 0V	-	-	-1.2	V
I <sub>S</sub>	Diode Continuous Forward Current		-	-	-5.1	A

### Ratings and Characteristics Curves-G<sub>1</sub> (@ T<sub>A</sub> = 25°C unless otherwise specified)

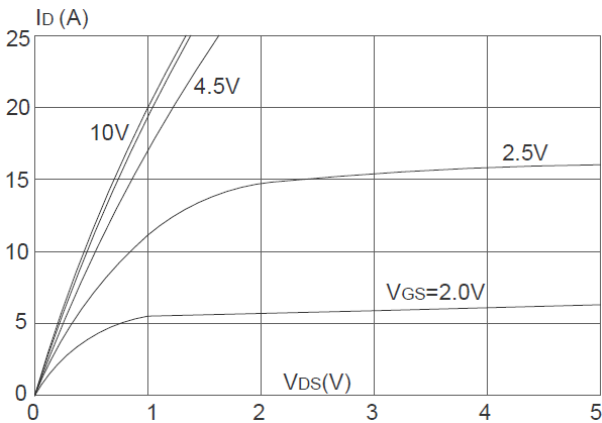


Fig 1 Typical Output Characteristics

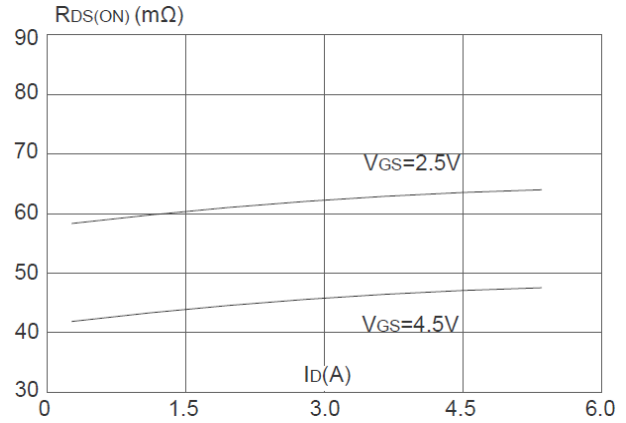


Fig 2 On-Resistance vs. Drain Current and Gate Voltage

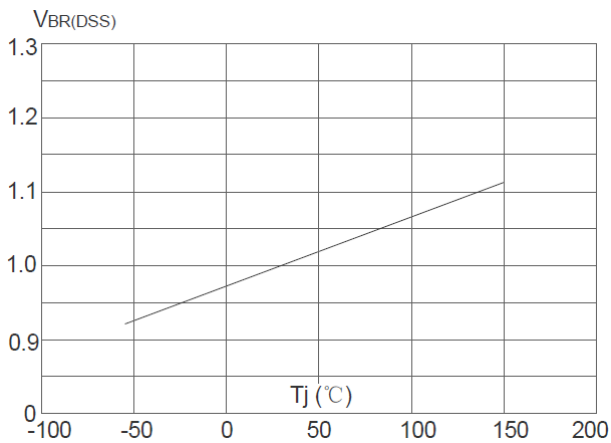


Fig 3 Normalized Breakdown Voltage vs. Junction Temperature

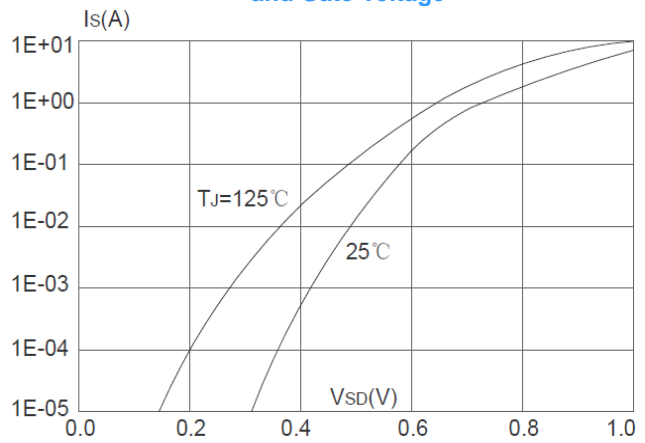


Fig 4 Body-Diode Characteristics

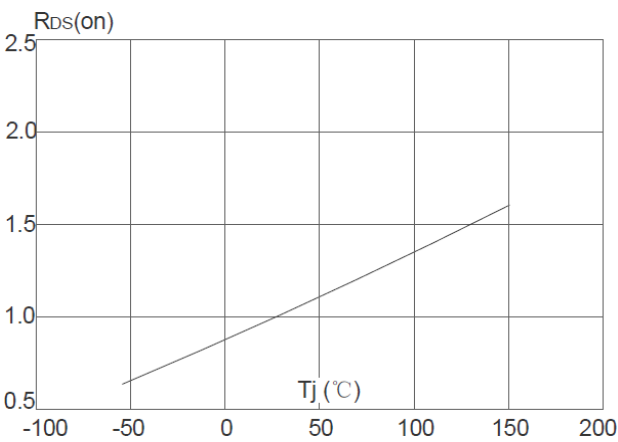


Fig 5 Normalized On-Resistance vs. Junction Temperature

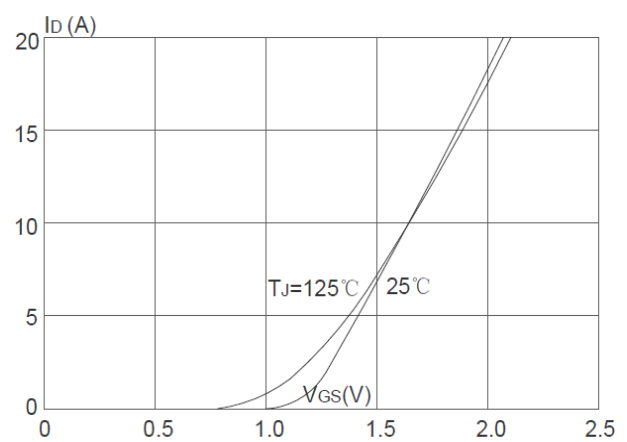


Fig 6 Transfer Characteristics

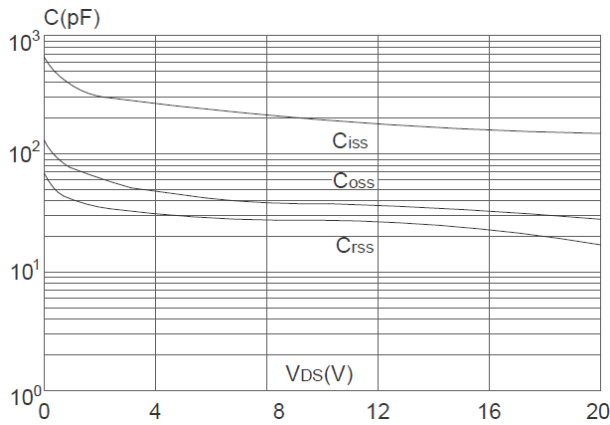


Fig 7 Capacitance Characteristics

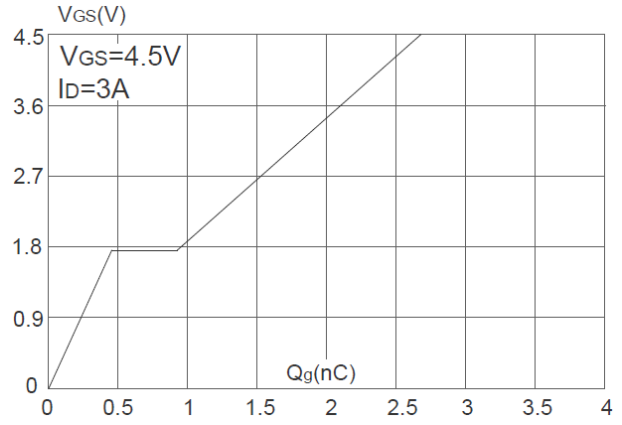


Fig 8 Gate-Charge Characteristics

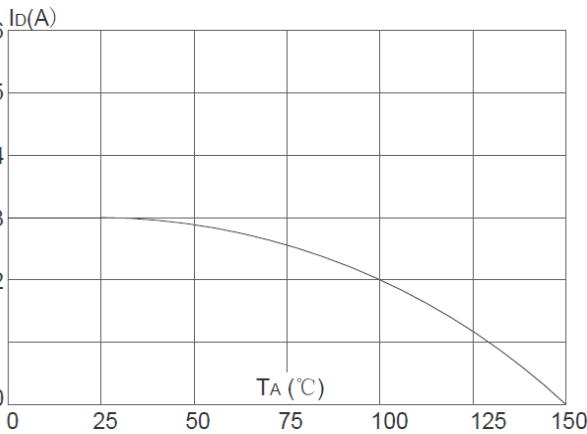


Fig 9 Maximum Continuous Drain Current vs. Ambient Temperature

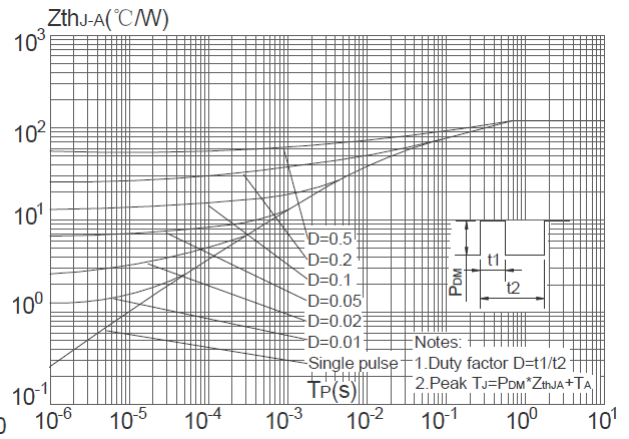


Fig 10 Maximum transient thermal impedance

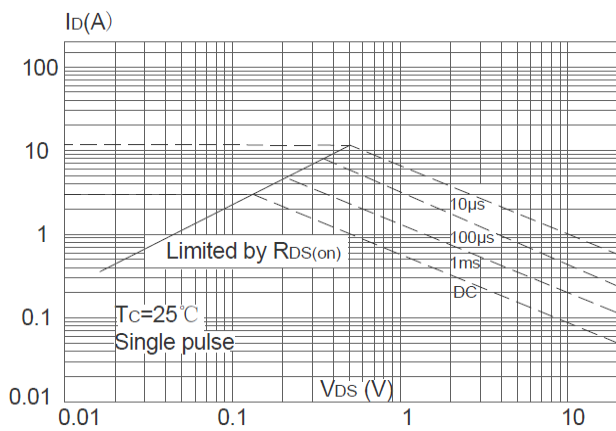
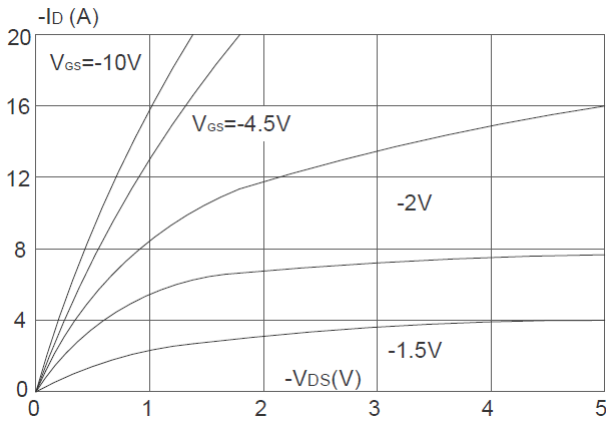
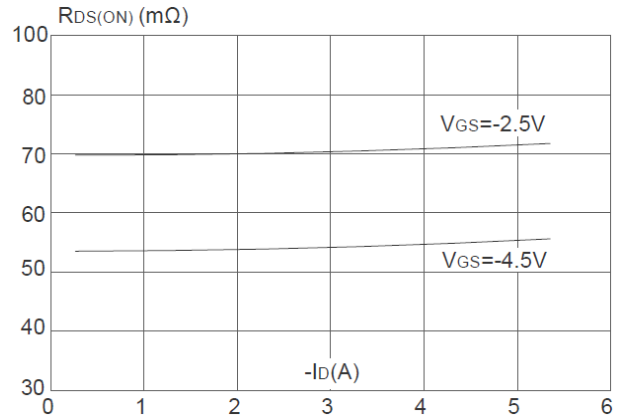


Fig 11 Safe Operation Area

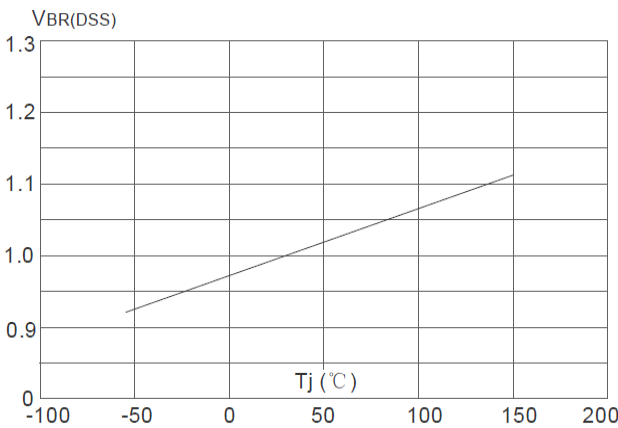
**Ratings and Characteristics Curves-G<sub>2</sub>** (@ T<sub>A</sub> = 25°C unless otherwise specified)



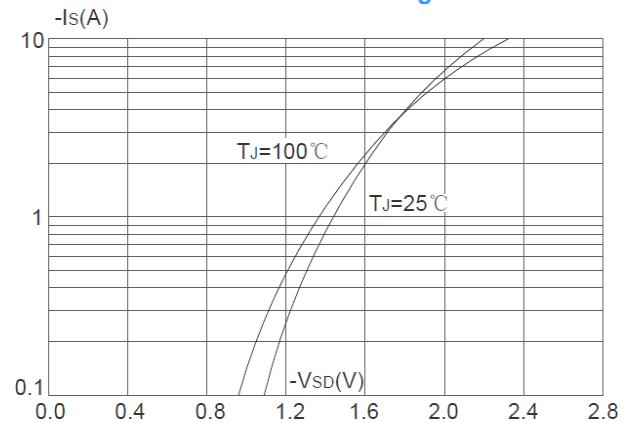
**Fig 1 Typical Output Characteristics**



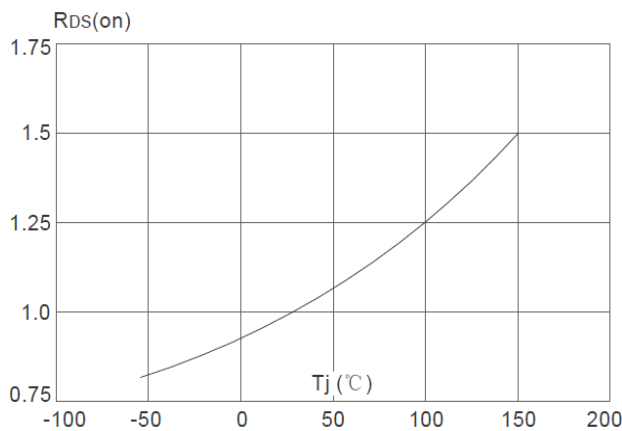
**Fig 2 On-Resistance vs. Drain Current and Gate Voltage**



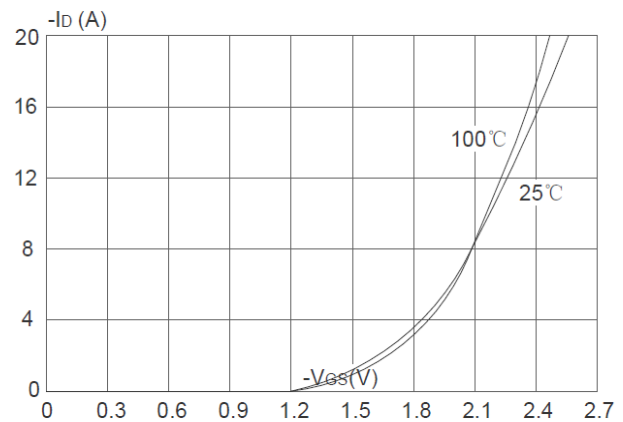
**Fig 3 Normalized Breakdown Voltage vs. Junction Temperature**



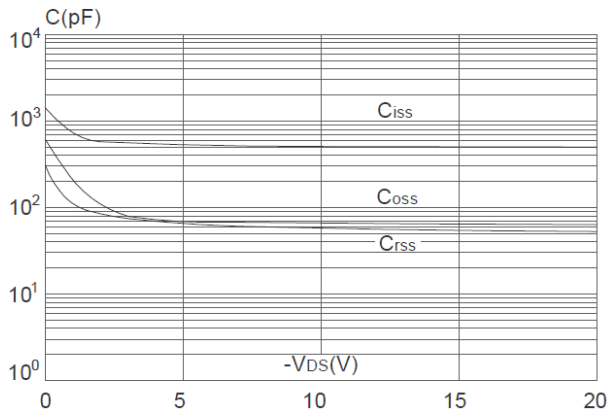
**Fig 4 Body-Diode Characteristics**



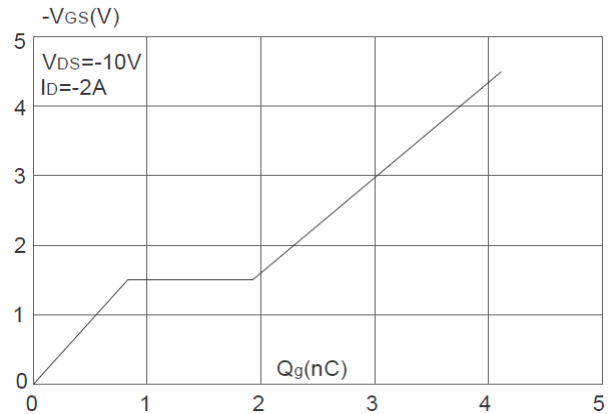
**Fig 5 Normalized On-Resistance vs. Junction Temperature**



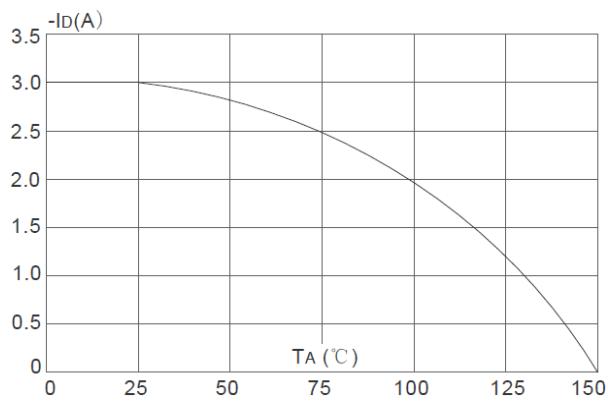
**Fig 6 Transfer Characteristics**



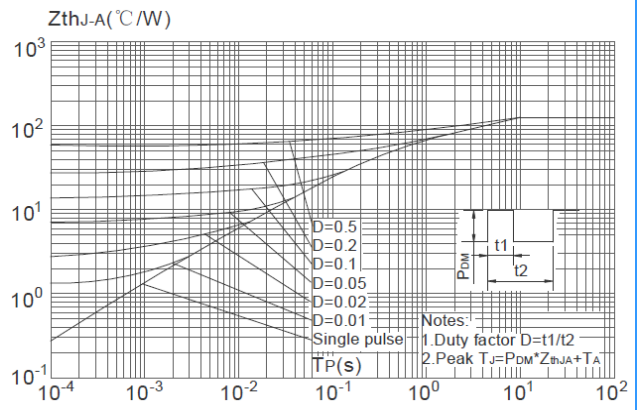
**Fig 7 Capacitance Characteristics**



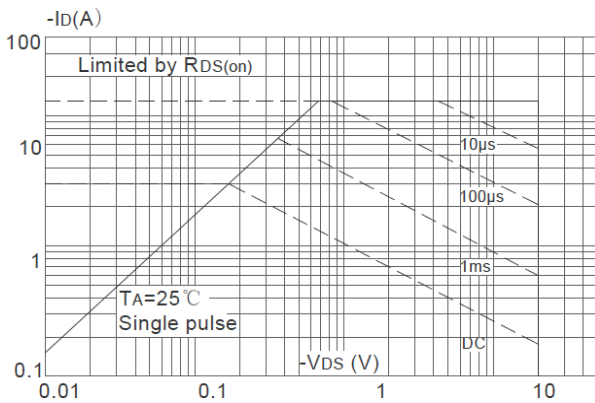
**Fig 8 Gate-Charge Characteristics**



**Fig 9 Maximum Continuous Drain Current vs. Ambient Temperature**

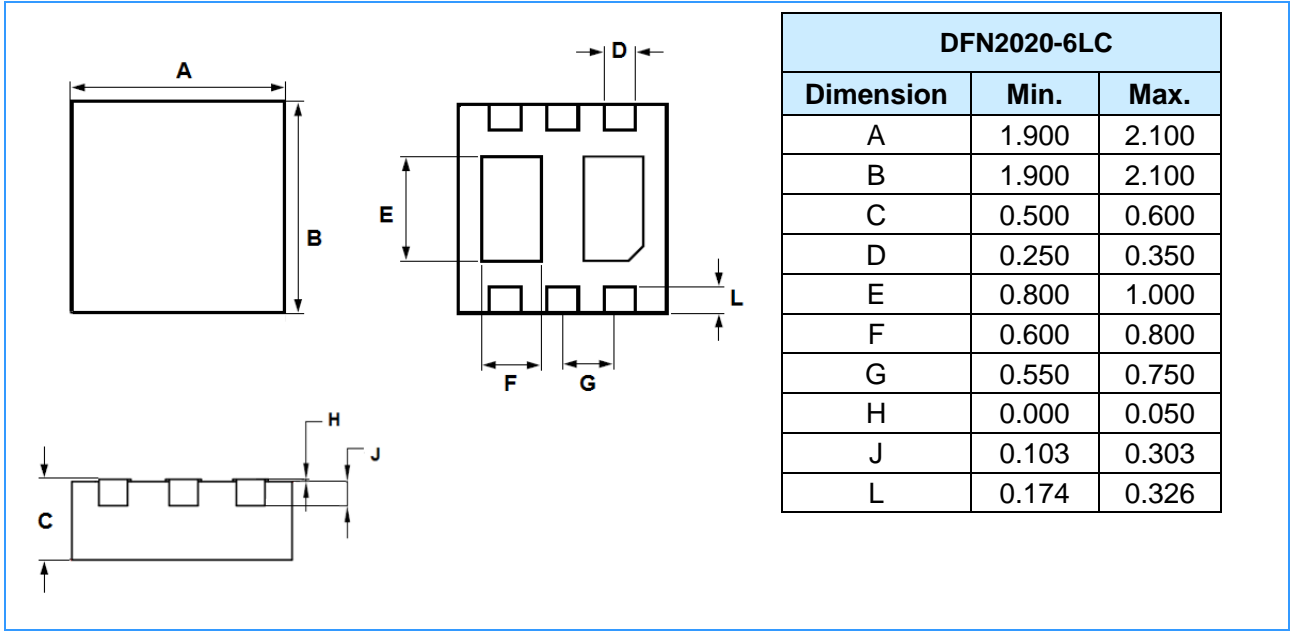


**Fig 10 Maximum transient thermal impedance**



**Fig 11 Safe Operation Area**

### Package Outline Dimensions (Unit: mm)



### Mounting Pad Layout (Unit: mm)

