

N-Channel MOSFET 300V,9A,450mΩ

BL9N30F

FEATURES

- 9.0 A, 300 V, $R_{DS(on)} = 450 \text{ m}\Omega$ (Max.)
- @ $V_{GS} = 10 \text{ V}$, $I_D = 4.5 \text{ A}$
- Low Gate Charge (Typ. 17 nC)
- Low Crss (Typ. 16 pF)
- 100% Avalanche Tested

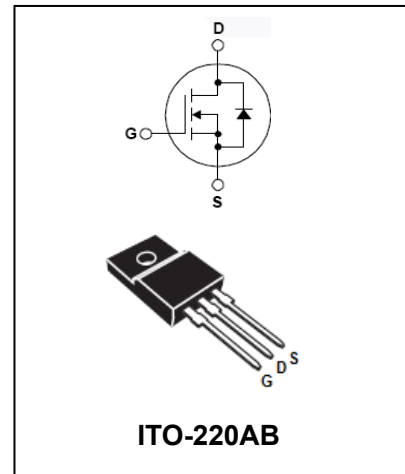

Applications

- Power switch circuit of adaptor and charger.

Ordering Information

Part Number	Package	Shipping	Marking Code
BL9N30F□	ITO-220AB	50/Tube	9N30F

□: none is for Lead Free package;

“G” is for Halogen Free package.

MAXIMUM RATING operating temperature range applies unless otherwise specified

Symbol	Parameter	Value	Units
V_{DS}	Drain-Source voltage	300	V
V_{GS}	Gate -Source voltage	± 30	V
I_D	Continuous Drain current	9.0	A
	Continuous Drain current $T_C=100^\circ\text{C}$	5.7	A
$I_{DM}(\text{Note1})$	Pulsed Drain current	36	A
$E_{AS}(\text{Note2})$	Single Pulse Avalanche Energy	420	mJ
$E_{AR}(\text{Note1})$	Avalanche Energy, Repetitive	9.8	mJ
$I_{AR}(\text{Note1})$	Avalanche Current	9.0	A
$dv/dt(\text{Note3})$	Peak Diode Recovery dv/dt	4.5	V/ns
P_D	Power Dissipation	98	W
	Derating Fcator above 25°C	0.78	W/ $^\circ\text{C}$
$R_{\theta JC}$	Junction-to-Case	1.28	$^\circ\text{C}/\text{W}$
$R_{\theta JA}$	Junction-to-Ambient	6.5	$^\circ\text{C}/\text{W}$
T_J, T_{stg}	Junction and Storage Temperature	-55 to +150	$^\circ\text{C}$
T_L	Maximum Temperature for Soldering	300	$^\circ\text{C}$

N-Channel MOSFET 300V,9A,450mΩ

BL9N30F

Note:1. Repetitive rating; pulse width limited by maximum junction temperature.

2. L=10mH, I_D=9A, Start T_J=25°C

3. I_{SD}=9A, di/dt ≤ 200A/us, V_{DD} ≤ BV_{DSS}, Start T_J=25°C

ELECTRICAL CHARACTERISTICS

Parameter	Symbol	Test conditions	MIN	TYP	MAX	UNIT
Off Characteristics						
Drain-Source Breakdown Voltage	V _{(BR)DSS}	V _{GS} =0V, I _D =250μA	300	-	-	V
Bvdss Temperature Coefficient	ΔBV _{DSS} /ΔT _J	I _D =250μA, Reference 25°C	-	0.28	-	V/°C
Drain to Source Leakage Current	I _{DSS}	V _{DS} =300V, V _{GS} =0V Ta=25°C	-	-	1	μA
		V _{DS} =240V, V _{GS} =0V Ta=125°C			10	
Gate-body Leakage Forward Reverse	I _{GSS}	V _{GS} = ± 30V			± 100	nA
On Characteristics						
Static drain-Source on-resistance	R _{DS(ON)}	V _{GS} =10V, I _D =4.5A	-	0.35	0.45	Ω
Gate Threshold Voltage	V _{GS(TH)}	V _{DS} = V _{GS} , I _D =250μA	3	-	5	V
Forward Transconductance	g _{fs}	V _{DS} =50V, I _D =4.5A	-	4.9	-	S
Dynamic Characteristics						
Input Capacitance	C _{iss}	V _{GS} = 0V V _{DS} = 25V f = 1.0MHz	-	570	740	pF
Output Capacitance	C _{oss}		-	120	155	
Reverse Transfer Capacitance	C _{riss}		-	16	20	
Switching Characteristics						
Turn-on Delay Time	td _(ON)	I _D =9A, V _{DD} = 150V R _G = 25Ω	-	16	40	ns
Rise Time	tr		-	120	250	
Turn-Off Delay Time	td _(OFF)		-	27	65	
Fall Time	tf		-	48	110	
Total Gate Charge	Q _g	I _D =9A V _{DD} =240V V _{GS} = 10V	-	17	22	nC
Gate to Source Charge	Q _{gs}		-	3.9	-	
Gate to Drain ("Miller") Charge	Q _{gd}		-	9.2	-	

N-Channel MOSFET 300V,9A,450mΩ

BL9N30F

Drain-Source Diode Characteristics and Maximum Ratings						
Drain-Source diode forward voltage	V_{SD}	$V_{GS}=0V, I_S=9A$	-	-	1.5	V
Maximum Continuous Drain-Source Diode Forward Current	I_S		-	-	9.0	A
Maximum Pulsed Drain-Source Diode Forward Current	I_{SM}		-	-	36	A

TYPICAL CHARACTERISTICS @ $T_a=25^\circ\text{C}$ unless otherwise specified

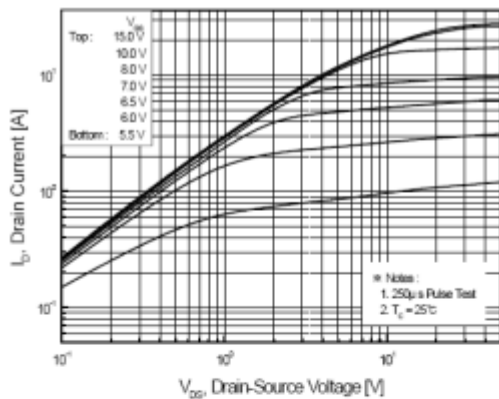

Figure 1. On-Region Characteristics

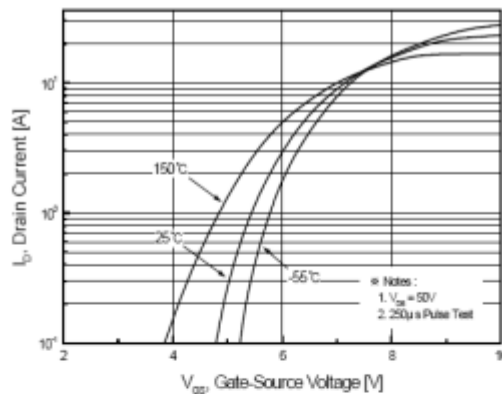

Figure 2. Transfer Characteristics

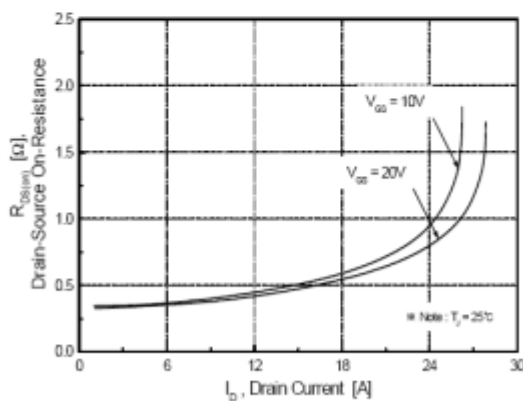

Figure 3. On-Resistance Variation vs. Drain Current and Gate Voltage

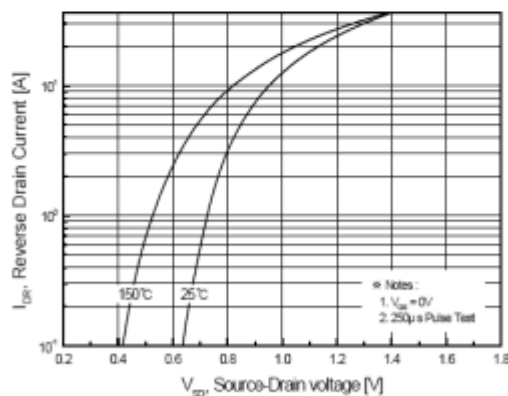

Figure 4. Body Diode Forward Voltage Variation vs. Source Current and Temperature

N-Channel MOSFET 300V,9A,450mΩ

BL9N30F

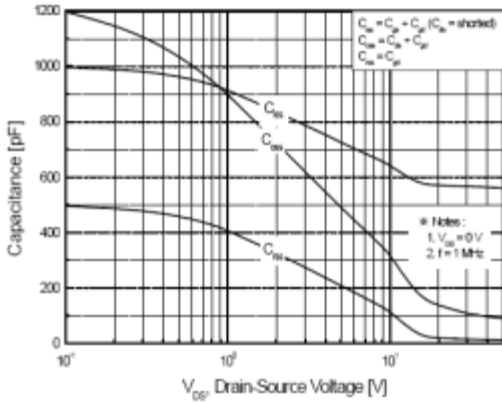

Figure 5. Capacitance Characteristics

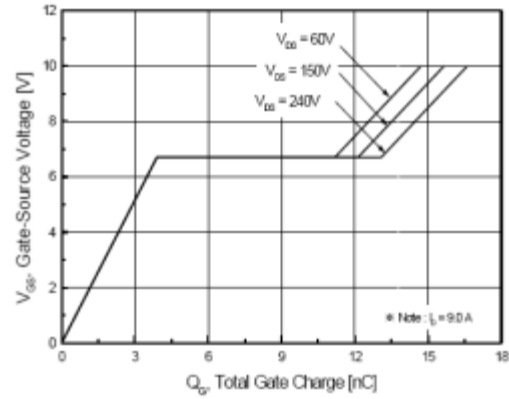

Figure 6. Gate Charge Characteristics

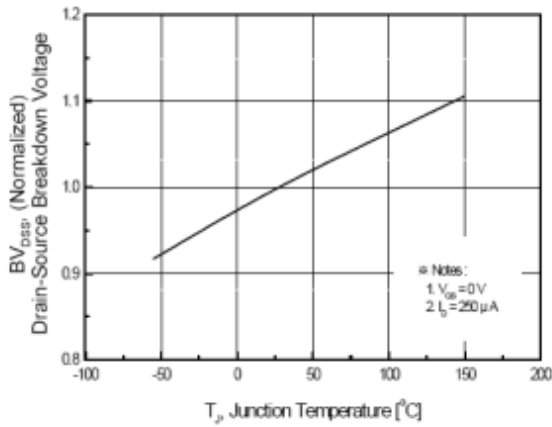

Figure 7. Breakdown Voltage Variation vs. Temperature

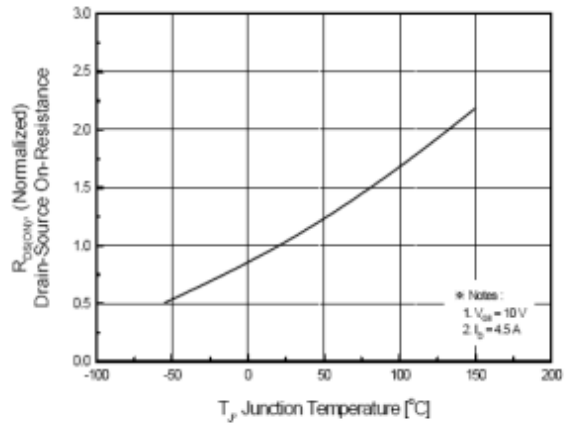

Figure 8. On-Resistance Variation vs. Temperature

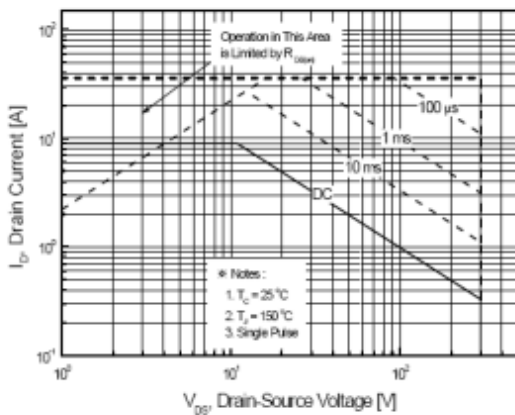

Figure 9. Maximum Safe Operating Area

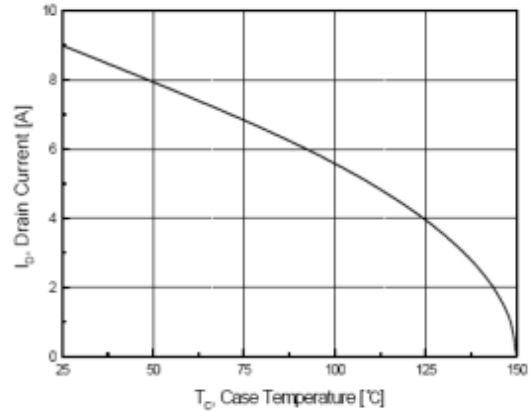

Figure 10. Maximum Drain Current vs. Case Temperature

N-Channel MOSFET 300V,9A,450mΩ

BL9N30F

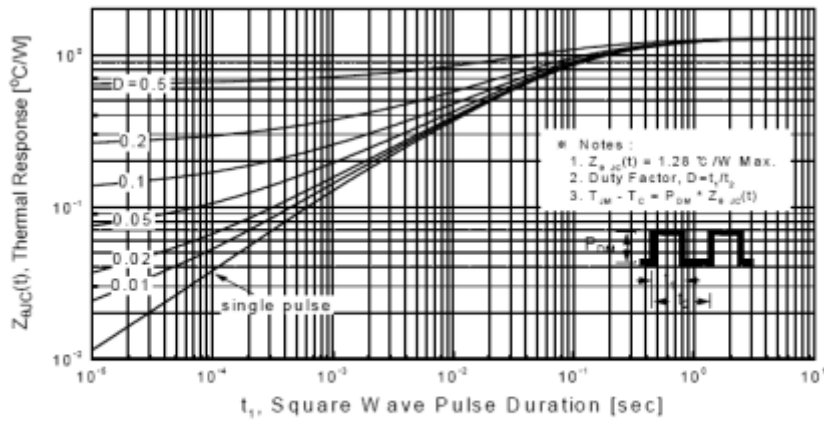

Figure 11. Transient Thermal Response Curve

PACKAGE OUTLINE

Plastic surface mounted package

ITO-220AB

