

Features

- Fast switching
- Low $R_{DS(ON)}$
- Low gate charge
- Low reverse transfer capacitances
- JESD22-A114-B ESD rating of class 1C per human body model

HF

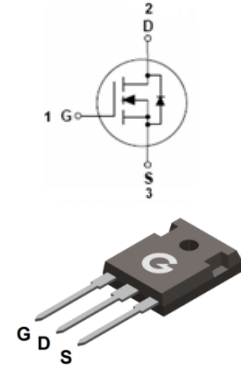

TO-247

Mechanical Data

- Case: TO-247
- Molding Compound: UL Flammability Classification Rating 94V-0
- Terminals: Matte tin-plated leads; solderability-per MIL-STD-202, Method 208

Ordering Information

Part Number	Package	Shipping Quantity	Marking Code
BL44N50U	TO-247	30 pcs / Tube	44N50U

Maximum Ratings (@ $T_C = 25^\circ\text{C}$ unless otherwise specified)

Parameter	Symbol	Value	Unit
Drain-to-Source Voltage	V_{DSS}	500	V
Gate-to-Source Voltage	V_{GSS}	± 30	V
Continuous Drain Current ($T_C = 25^\circ\text{C}$)	I_D	44	A
Continuous Drain Current ($T_C = 100^\circ\text{C}$)		32	A
Pulsed Drain Current ($t_p = 10\mu\text{s}$, $T_C = 25^\circ\text{C}$)	I_{DM}	176	A
Single Pulse Avalanche Energy ²	E_{AS}	2500	mJ
Power Dissipation ($T_C = 25^\circ\text{C}$)	P_D	750	W
Operating Junction Temperature Range	T_J	-55 ~ +175	$^\circ\text{C}$
Storage Temperature Range	T_{STG}	-55 ~ +175	$^\circ\text{C}$

Thermal Characteristics

Parameter	Symbol	Min.	Typ.	Max.	Unit
Thermal Resistance Junction-to-Case	$R_{\theta JC}$	-	0.15	0.2	$^\circ\text{C/W}$
Thermal Resistance Junction-to-Air	$R_{\theta JA}$	-	10	20	$^\circ\text{C/W}$

Electrical Characteristics (@ $T_A = 25^\circ\text{C}$ unless otherwise specified)

Symbol	Parameter	Test Condition	Min.	Typ.	Max.	Unit
Static Characteristics						
V_{DSS}	Drain-Source Breakdown Voltage	$V_{GS} = 0V, I_D = 250\mu A$	500	-	-	V
I_{DSS}	Zero Gate Voltage Drain Current	$V_{DS} = 500V, V_{GS} = 0V$	-	-	1	μA
I_{GSS}	Gate-Body Leakage Current	$V_{GS} = \pm 30V, V_{DS} = 0V$	-	-	± 100	nA
On Characteristics						
$R_{DS(ON)}$	Drain-Source On-resistance *1	$V_{GS} = 10V, I_D = 22A$	-	95	120	m Ω
$V_{GS(th)}$	Gate Threshold Voltage	$V_{DS} = V_{GS}, I_D = 250\mu A$	2.5	3.7	4.5	V
R_G	Gate Resistance	$V_{GS} = 0V, f = 1MHz$	-	4	-	Ω
Dynamic Characteristics						
C_{ISS}	Input Capacitance	$V_{GS} = 0V$	-	7881	-	pF
C_{OSS}	Output Capacitance	$V_{DS} = 25V$	-	701	-	
C_{RSS}	Reverse Transfer Capacitance	$f = 1.0MHz$	-	40	-	
Switching Characteristics						
$t_{d(ON)}$	Turn-on Delay Time	$V_{DD} = 250V$	-	40	-	ns
t_r	Turn-on Rise Time	$V_{GS} = 15V$	-	68	-	
$t_{d(OFF)}$	Turn-Off Delay Time	$I_D = 44A$	-	110	-	
t_f	Turn-Off Fall Time	$R_G = 2\Omega$	-	78	-	
Q_G	Total Gate-Charge	$V_{DD} = 400V$	-	145	-	nC
Q_{GS}	Gate to Source Charge	$V_{GS} = 10V$	-	41	-	
Q_{GD}	Gate to Drain (Miller) Charge	$I_D = 30A$	-	50	-	
Source-Drain Diode Characteristics						
V_{SD}	Diode Forward Voltage *1	$I_{SD} = 30A, V_{GS} = 0V$	-	0.9	1.5	V
t_{rr}	Reverse Recovery Time	$I_F = 30A, V_{GS} = 0V$	-	650	-	ns
Q_{rr}	Reverse Recovery Charge	$di/dt = 100A/\mu s$	-	8.9	-	μC

Notes:

- The data tested by pulsed, pulse width $\leq 300\mu s$, duty cycle $\leq 2\%$
- The E_{AS} data shows Max. rating. The test condition is $V_{DD} = 50V, V_{GS} = 15V, L = 10mH$

Ratings and Characteristics Curves (@ $T_A = 25^\circ\text{C}$ unless otherwise specified)

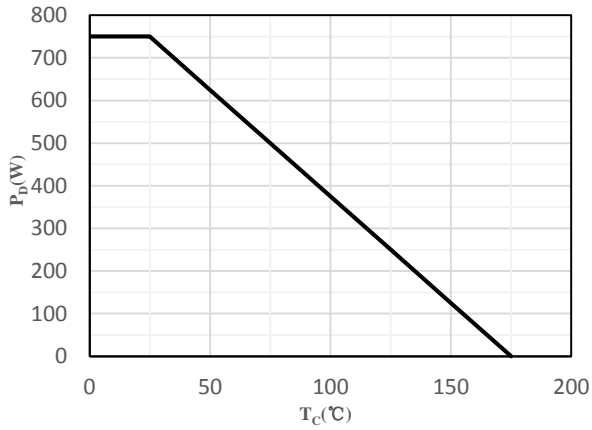

Fig 1 Power Dissipation

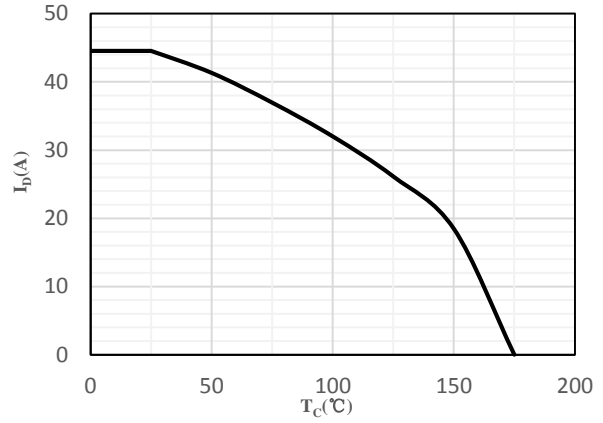

Fig 2 Drain Current

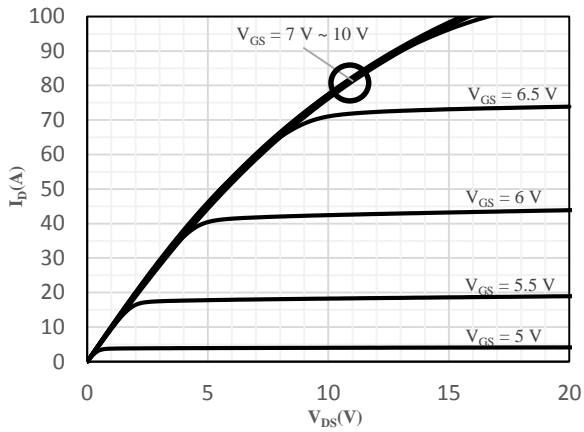

Fig 3 Typical Output Characteristics

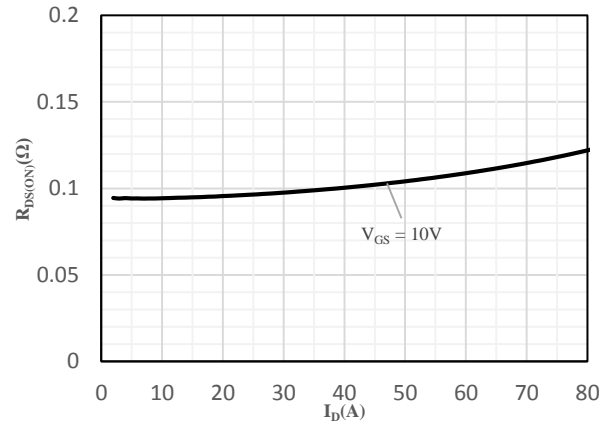

Fig 4 On-Resistance vs. Drain Current and Gate Voltage

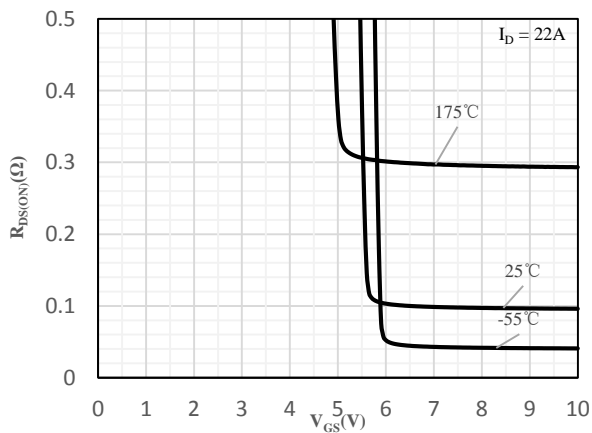

Fig 5 On-Resistance vs. Gate-Source Voltage

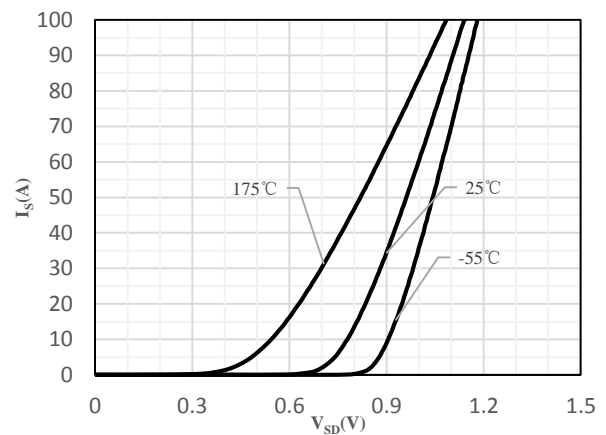

Fig 6 Body-Diode Characteristics

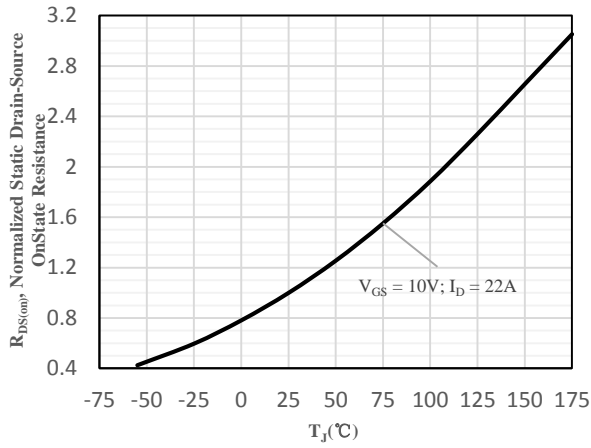

Fig 7 Normalized On-Resistance vs. Junction Temperature

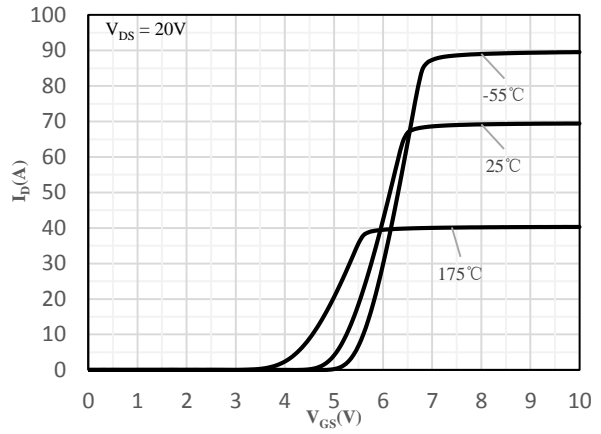

Fig 8 Transfer Characteristics

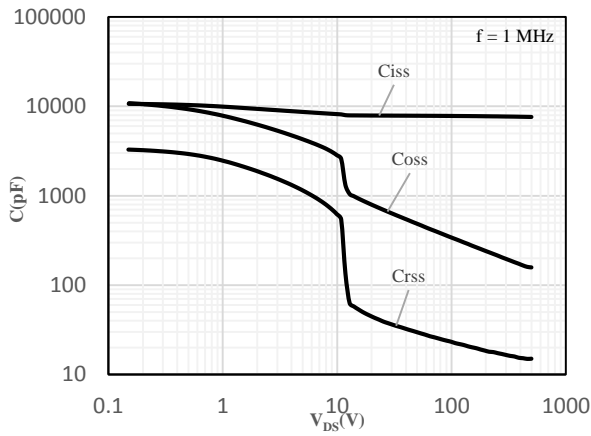

Fig 9 Capacitance Characteristics

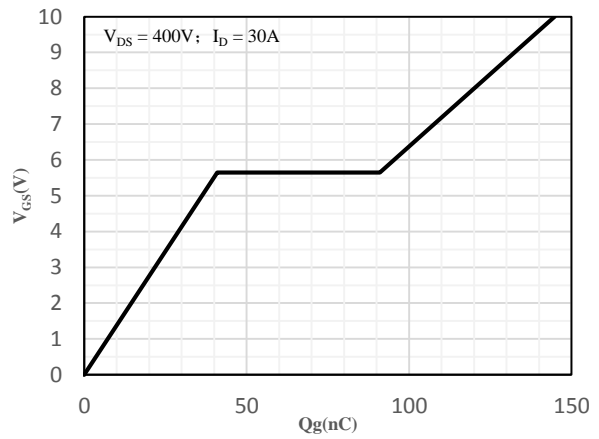

Fig 10 Gate-Charge Characteristics

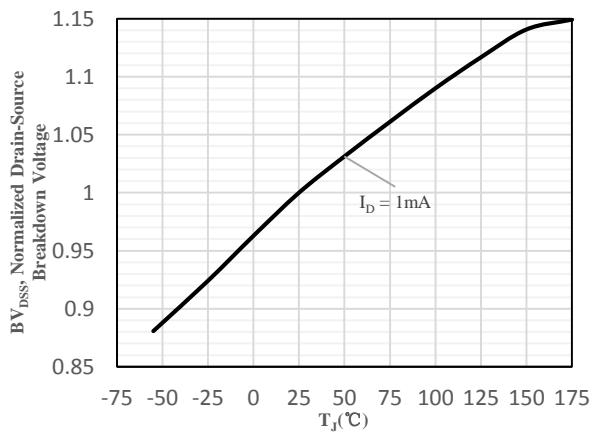

Fig 11 Normalized Breakdown Voltage vs. Junction Temperature

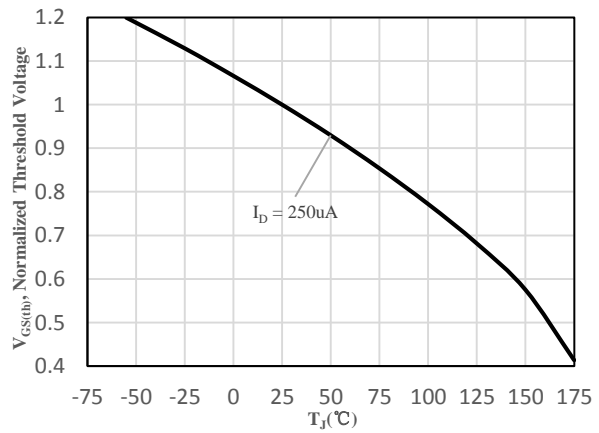

Fig 12 Normalized $V_{GS(th)}$ vs. Junction Temperature

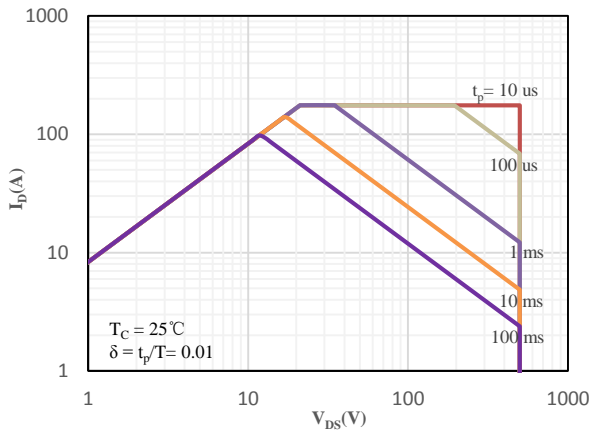

Fig 13 Safe Operation Area

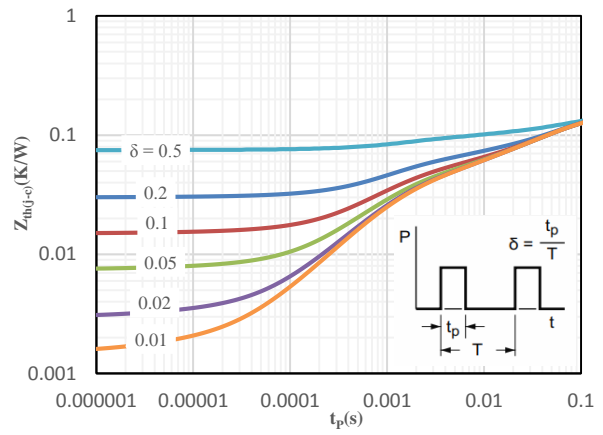
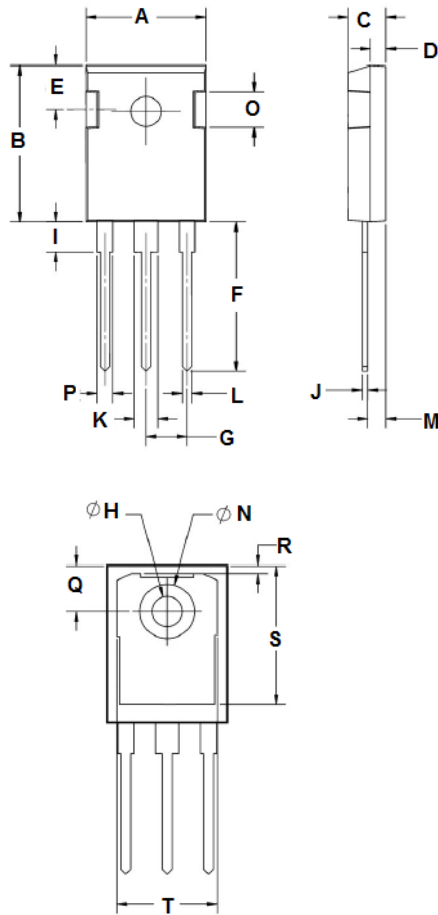

Fig 14 Maximum transient thermal impedance

Package Outline Dimensions (Unit: mm)



TO-247		
Dimension	Min.	Max.
A	15.50	16.10
B	20.70	21.30
C	4.70	5.30
D	1.80	2.20
E	5.20	5.80
F	19.70	20.30
G	5.20	5.60
H	3.30	3.70
I	3.90	4.30
J	0.50	0.70
K	2.80	3.20
L	1.00	1.40
M	2.20	2.60
N	7.00	7.20
O	4.90	5.30
P	1.80	2.20
Q	5.70	5.90
R	0.80	1.20
S	17.00	17.80
T	13.60	14.20

Important Notice

Changzhou Galaxy Century Microelectronics (GME) reserves the right to make changes without further notice to any product information (copyrighted) herein to make corrections, modifications, improvements, or other changes. GME does not assume any liability arising out of the application or use of any product described herein; neither does it convey any license under its patent rights, nor the rights of others.