

### Features

- Planar technology
- Low on-resistance
- Low gate charge
- Low reverse transfer capacitances
- HBM: JESD22-A114-B: 1C
- RoHS compliant with Halogen-free

HF

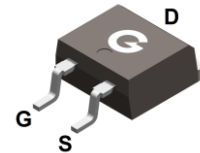
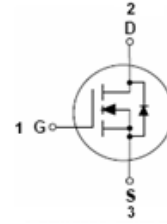

TO-263-2L

### Mechanical Data

- Case: TO-263-2L
- Molding Compound: UL Flammability Classification Rating 94V-0
- Terminals: Matte Tin-Plated Leads, Solderability-per MIL-STD-202, Method 208

### Ordering Information

Part Number	Package	Shipping Quantity	Marking Code
BL3N1K5B2	TO-263-2L	50 pcs / Tube or 800 pcs / Tape & Reel	3N1K5B2

### Maximum Ratings (@ T<sub>c</sub> = 25°C unless otherwise specified)

Parameter	Symbol	Value	Unit
Drain-to-Source Voltage	V <sub>DSS</sub>	1500	V
Gate-to-Source Voltage	V <sub>GSS</sub>	±30	V
Continuous Drain Current (T <sub>c</sub> = 25°C)	I <sub>D</sub>	3	A
Continuous Drain Current (T <sub>c</sub> = 100°C)		1.9	
Pulsed Drain Current (t <sub>p</sub> = 10μs, T <sub>c</sub> = 25°C)	I <sub>DM</sub>	12	A
Single Pulse Avalanche Energy <sup>2</sup>	E <sub>AS</sub>	30	mJ
Power Dissipation (T <sub>c</sub> = 25°C)	P <sub>D</sub>	200	W
Operating Junction Temperature Range	T <sub>J</sub>	-55 ~ +150	°C
Storage Temperature Range	T <sub>STG</sub>	-55 ~ +150	°C

### Thermal Characteristics

Parameter	Symbol	Min.	Typ.	Max.	Unit
Thermal Resistance Junction-to-Case	R <sub>θJC</sub>	-	-	0.62	°C/W
Thermal Resistance Junction-to-Air	R <sub>θJA</sub>	-	-	50	°C/W

### Electrical Characteristics (@ $T_A = 25^\circ\text{C}$ unless otherwise specified)

Symbol	Parameter	Test Condition	Min.	Typ.	Max.	Unit
<b>Static Characteristics</b>						
$V_{DSS}$	Drain-Source Breakdown Voltage	$V_{GS} = 0V, I_D = 250\mu A$	1500	-	-	V
$I_{DSS}$	Zero Gate Voltage Drain Current	$V_{DS} = 1500V, V_{GS} = 0V$	-	-	25	$\mu A$
$I_{GSS}$	Gate-Body Leakage Current	$V_{GS} = \pm 30V, V_{DS} = 0V$	-	-	$\pm 100$	nA
<b>On Characteristics</b>						
$R_{DS(ON)}$	Drain-Source On-resistance <sup>*1</sup>	$V_{GS} = 10V, I_D = 1.5A$	-	5.5	8	$\Omega$
$V_{GS(th)}$	Gate Threshold Voltage	$V_{DS} = V_{GS}, I_D = 250\mu A$	2.5	3.5	5	V
$R_G$	Gate Resistance	$V_{GS} = 0V, f = 1MHz$	-	2	-	$\Omega$
<b>Dynamic Characteristics</b>						
$C_{ISS}$	Input Capacitance	$V_{GS} = 0V$	-	1728	-	pF
$C_{OSS}$	Output Capacitance	$V_{DS} = 25V$	-	101	-	
$C_{RSS}$	Reverse Transfer Capacitance	$f = 1.0MHz$	-	8.9	-	
<b>Switching Characteristics</b>						
$t_{d(ON)}$	Turn-on Delay Time <sup>*3</sup>	$V_{DD} = 750V$ $V_{GS} = 10V$ $I_D = 3A$ $R_G = 4.7\Omega$	-	25	-	ns
$t_r$	Turn-on Rise Time <sup>*3</sup>		-	48	-	
$t_{d(OFF)}$	Turn-Off Delay Time <sup>*3</sup>		-	57	-	
$t_f$	Turn-Off Fall Time <sup>*3</sup>		-	52	-	
$Q_G$	Total Gate-Charge	$V_{DD} = 960V$	-	45	-	nC
$Q_{GS}$	Gate to Source Charge	$V_{GS} = 10V$	-	7.5	-	
$Q_{GD}$	Gate to Drain ( "Miller" ) Charge	$I_D = 3A$	-	21.2	-	
<b>Source-Drain Diode Characteristics</b>						
$V_{SD}$	Diode Forward Voltage <sup>*1</sup>	$I_{SD} = 3A, V_{GS} = 0V$	-	0.8	1.5	V
$t_{rr}$	Body Diode Reverse Recovery Time	$I_F = 1.5A, V_R = 100V$	-	1	-	$\mu s$
$Q_{rr}$	Body Diode Reverse Recovery Charge	$di/dt = 100A/\mu s$	-	6.6	-	$\mu C$

Notes:

1. The data tested by pulsed, pulse width  $\leq 300\mu s$ , duty cycle  $\leq 2\%$
2. The  $E_{AS}$  data shows Max. rating. The test condition is  $V_{DD} = 50V, V_{GS} = 15V, L = 10mH$
3. Guaranteed by design, not subject to production

**Ratings and Characteristic Curves** (@  $T_A = 25^\circ\text{C}$  unless otherwise specified)

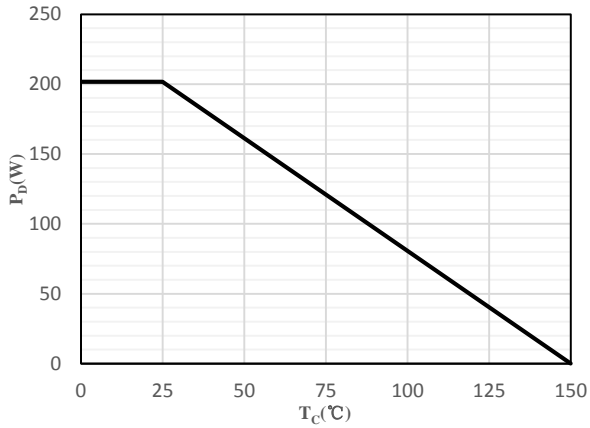

**Fig 1 Power Dissipation**

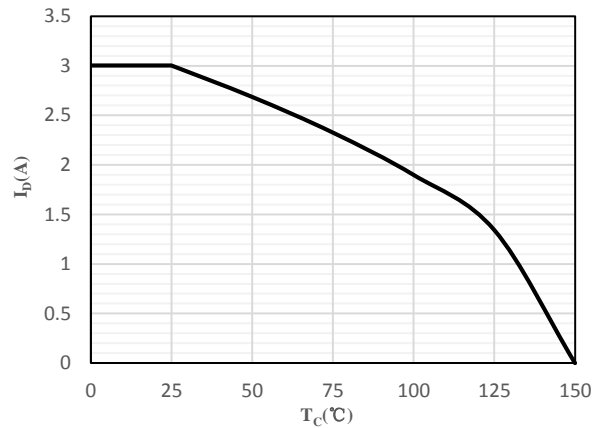

**Fig 2 Drain Current**

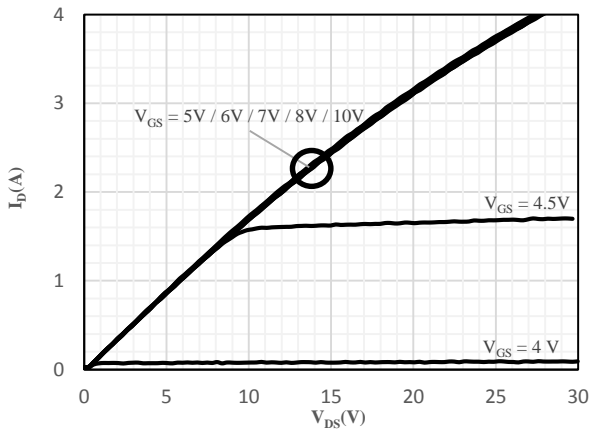

**Fig 3 Typical Output Characteristics ( $T_J = 25^\circ\text{C}$ )**

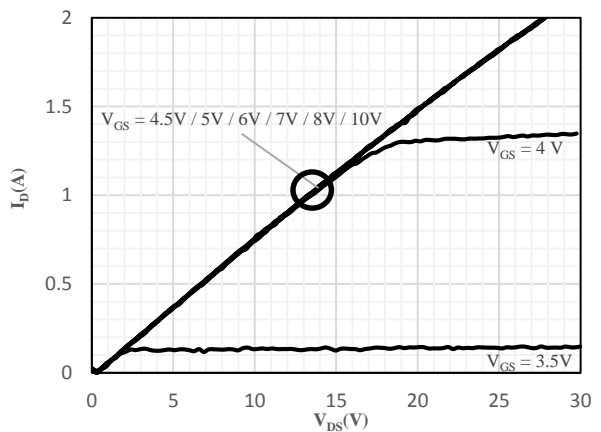

**Fig 4 Typical Output Characteristics ( $T_J = 125^\circ\text{C}$ )**

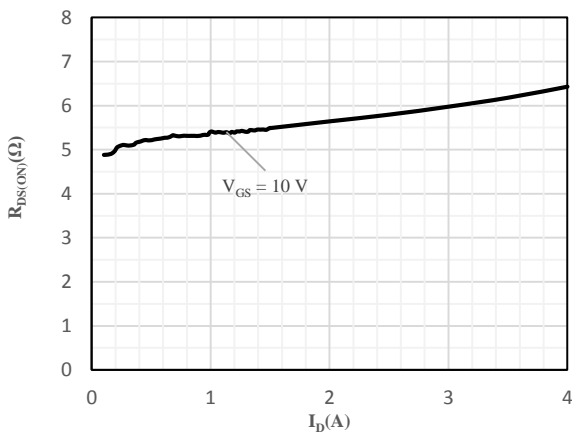

**Fig 5 On-Resistance vs. Drain Current and Gate Voltage**

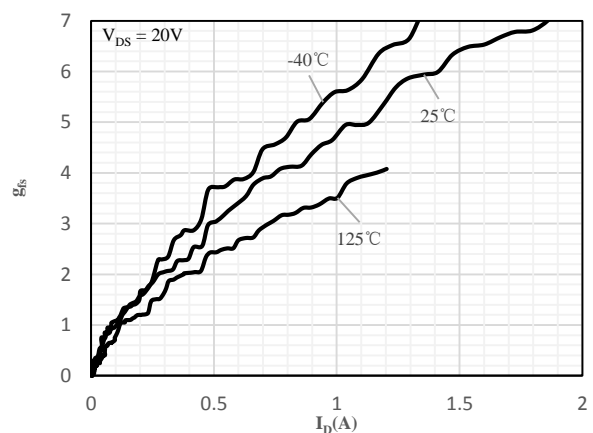

**Fig 6 Transconductance vs. Drain Current**

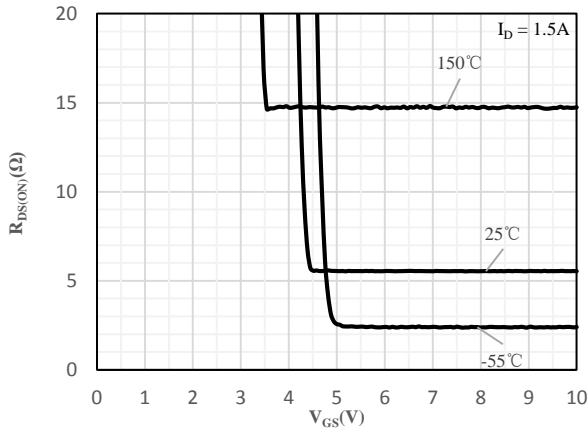

Fig 7 On-Resistance vs. Gate-Source Voltage

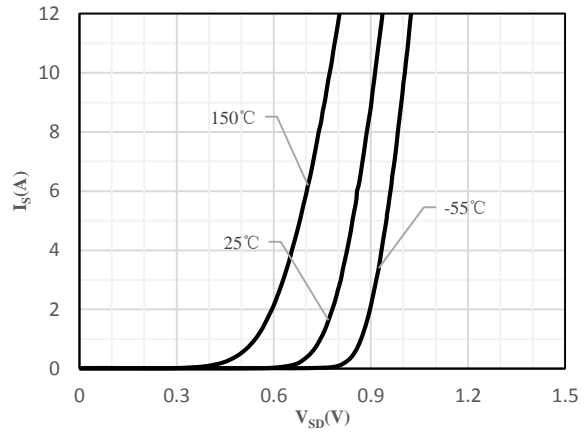

Fig 8 Body-Diode Characteristics

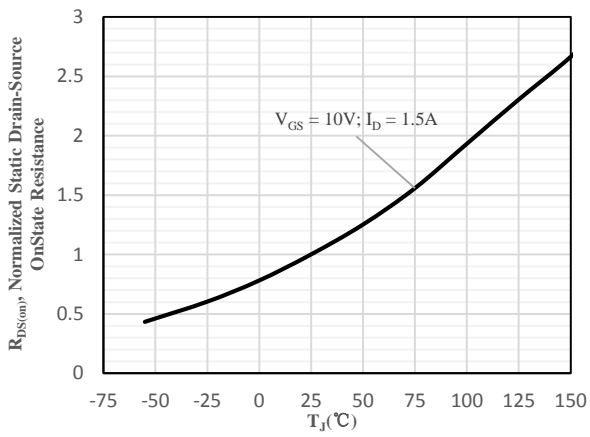

Fig 9 Normalized On-Resistance vs. Junction Temperature

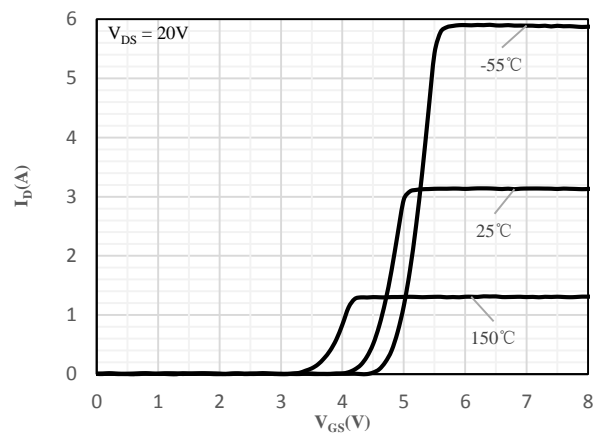

Fig 10 Transfer Characteristics

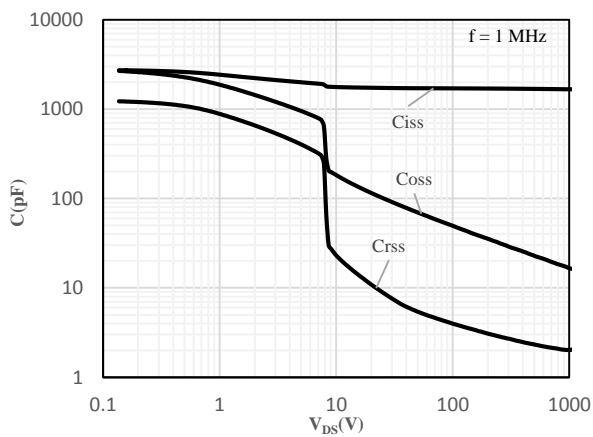

Fig 11 Capacitance Characteristics

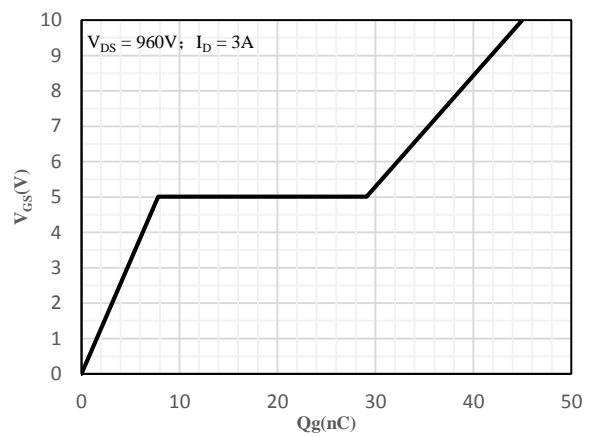

Fig 12 Gate-Charge Characteristics

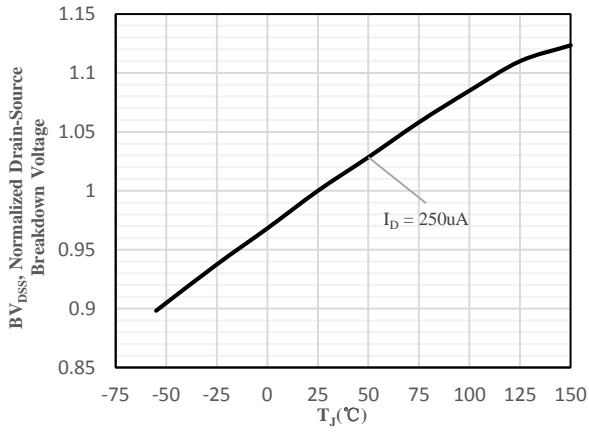

Fig 13 Normalized Breakdown Voltage vs. Junction Temperature

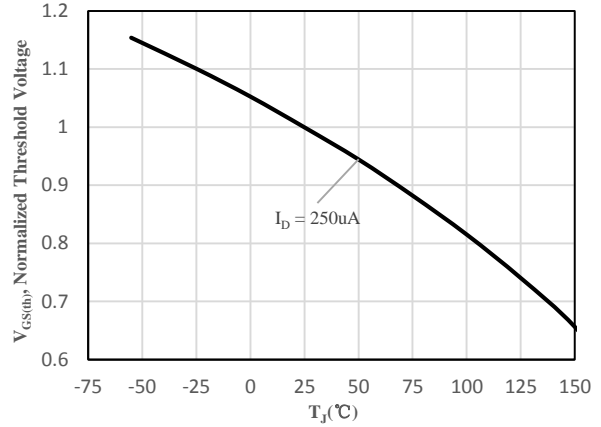

Fig 14 Normalized  $V_{GS(th)}$  vs. Junction Temperature

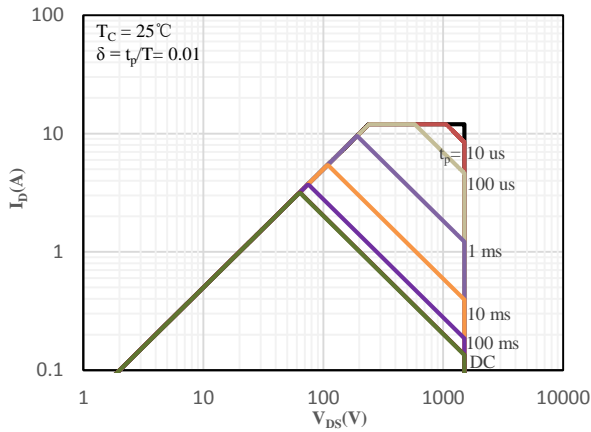

Fig 15 Safe Operating Area

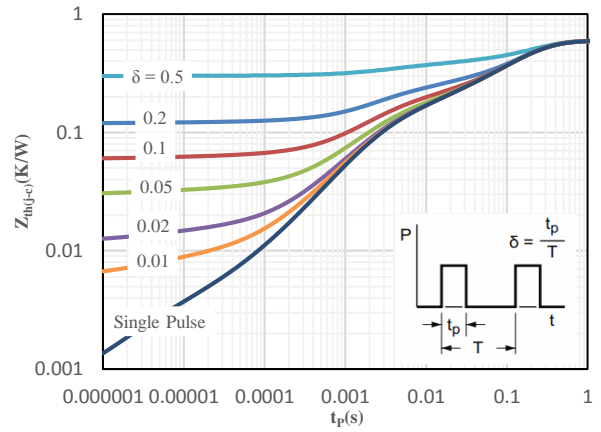
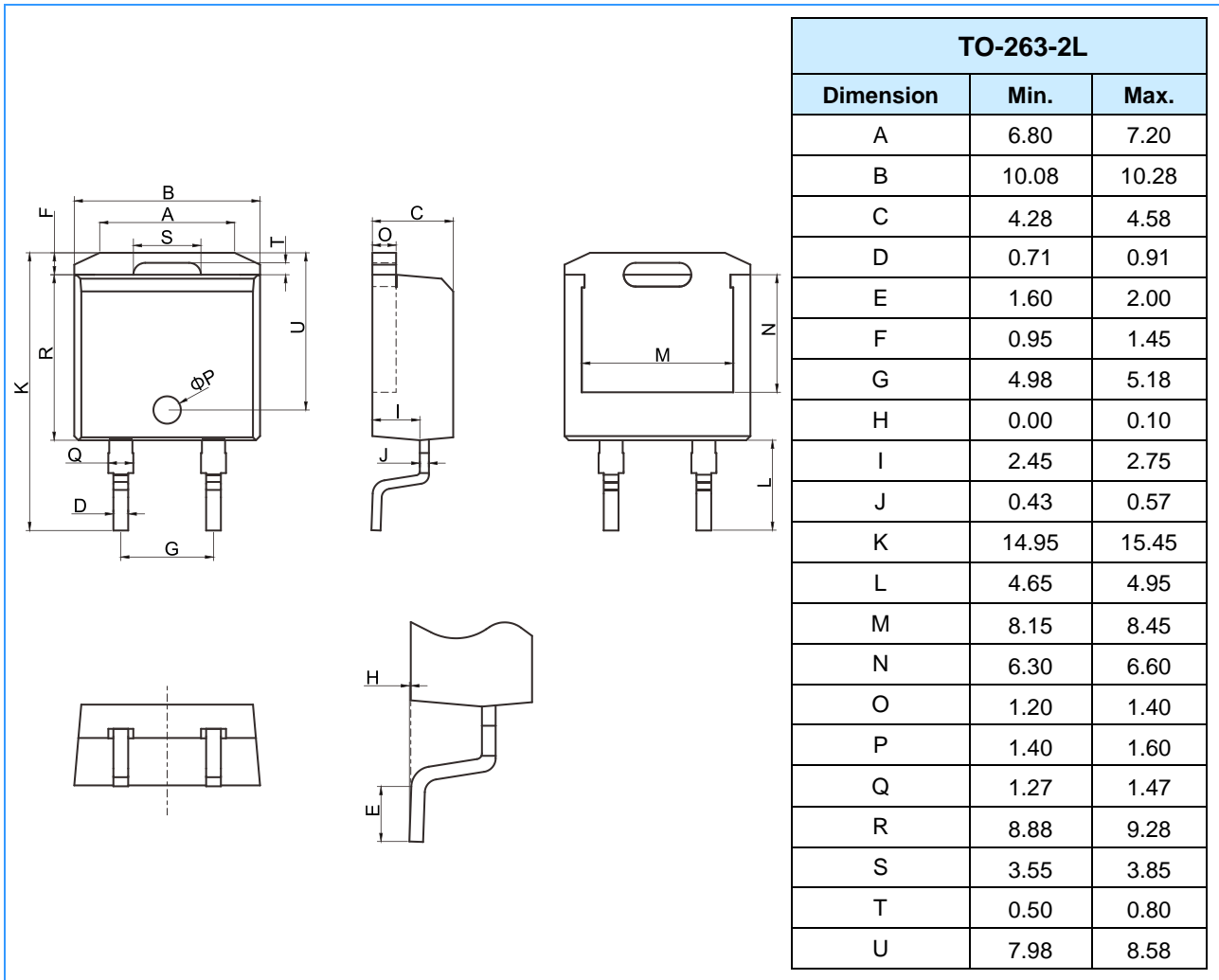

Fig 16 Maximum transient thermal impedance

### Package Outline Dimensions (Unit: mm)



### Mounting Pad Layout (Unit: mm)

