

Features

- Fast switching
- Low $R_{DS(ON)}$
- Low gate charge
- Advanced high cell density trench technology
- RoHS compliant with Halogen-free

HF

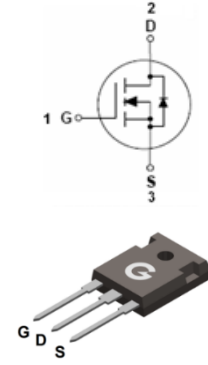

TO-247

Mechanical Data

- Case: TO-247
- Molding Compound: UL Flammability Classification Rating 94V-0
- Terminals: Matte tin-plated leads; solderability-per MIL-STD-202, Method 208

Ordering Information

Part Number	Package	Shipping Quantity	Marking Code
BL20N90U	TO-247	30 pcs / Tube	20N90U

Maximum Ratings (@ $T_C = 25^\circ\text{C}$ unless otherwise specified)

Parameter	Symbol	Value	Unit
Drain-to-Source Voltage	V_{DSS}	900	V
Gate-to-Source Voltage	V_{GSS}	± 30	V
Continuous Drain Current ($T_C = 25^\circ\text{C}$)	I_D	20	A
Continuous Drain Current ($T_C = 100^\circ\text{C}$)		12.5	A
Pulsed Drain Current ($t_p = 10\mu\text{s}$, $T_C = 25^\circ\text{C}$)	I_{DM}	80	A
Single Pulse Avalanche Energy ²	E_{AS}	500	mJ
Power Dissipation ($T_C = 25^\circ\text{C}$)	P_D	250	W
Operating Junction Temperature Range	T_J	-55 ~ +150	$^\circ\text{C}$
Storage Temperature Range	T_{STG}	-55 ~ +150	$^\circ\text{C}$

Thermal Characteristics

Parameter	Symbol	Min.	Typ.	Max.	Unit
Thermal Resistance Junction-to-Case	$R_{\theta JC}$	-	-	0.5	$^\circ\text{C/W}$
Thermal Resistance Junction-to-Air	$R_{\theta JA}$	-	-	40	$^\circ\text{C/W}$

Electrical Characteristics (@ $T_A = 25^\circ\text{C}$ unless otherwise specified)

Symbol	Parameter	Test Condition	Min.	Typ.	Max.	Unit
Static Characteristics						
V_{DSS}	Drain-Source Breakdown Voltage	$V_{GS} = 0V, I_D = 250\mu A$	900	-	-	V
I_{DSS}	Zero Gate Voltage Drain Current	$V_{DS} = 900V, V_{GS} = 0V$	-	-	25	μA
I_{GSS}	Gate-Body Leakage Current	$V_{GS} = \pm 30V, V_{DS} = 0V$	-	-	± 100	nA
On Characteristics						
$R_{DS(ON)}$	Drain-Source On-resistance *1	$V_{GS} = 10V, I_D = 10A$	-	-	0.4	Ω
$V_{GS(th)}$	Gate Threshold Voltage	$V_{DS} = V_{GS}, I_D = 250\mu A$	2	-	4	V
Dynamic Characteristics						
C_{ISS}	Input Capacitance	$V_{GS} = 0V$	-	7904	-	pF
C_{OSS}	Output Capacitance	$V_{DS} = 25V$	-	494	-	
C_{RSS}	Reverse Transfer Capacitance	$f = 100kHz$	-	18	-	
Switching Characteristics						
$t_{d(ON)}$	Turn-on Delay Time *3	$V_{DD} = 450V$ $I_D = 20A$ $R_G = 25\Omega$	-	63	-	ns
t_r	Turn-on Rise Time *3		-	89	-	
$t_{d(OFF)}$	Turn-Off Delay Time *3		-	135	-	
t_f	Turn-Off Fall Time *3		-	59	-	
Q_G	Total Gate-Charge	$V_{DD} = 720V$	-	141	-	nC
Q_{GS}	Gate to Source Charge	$V_{GS} = 10V$	-	38	-	
Q_{GD}	Gate to Drain (Miller) Charge	$I_D = 20A$	-	48	-	
Source-Drain Diode Characteristics						
V_{SD}	Diode Forward Voltage *1	$I_{SD} = 20A, V_{GS} = 0V$	-	-	1.5	V
t_{rr}	Reverse Recovery Time	$I_S = 20A, V_{GS} = 0V$	-	932	-	ns
Q_{rr}	Reverse Recovery Charge	$di/dt = 100A/\mu s$	-	13.9	-	μC

Notes:

- The data tested by pulsed, pulse width $\leq 300\mu s$, duty cycle $\leq 2\%$
- The E_{AS} data shows Max. rating. The test condition is $V_{DD} = 50V, V_{GS} = 15V, L = 10mH$
- Guaranteed by design, not subject to production testing

Ratings and Characteristics Curves (@ $T_A = 25^\circ\text{C}$ unless otherwise specified)

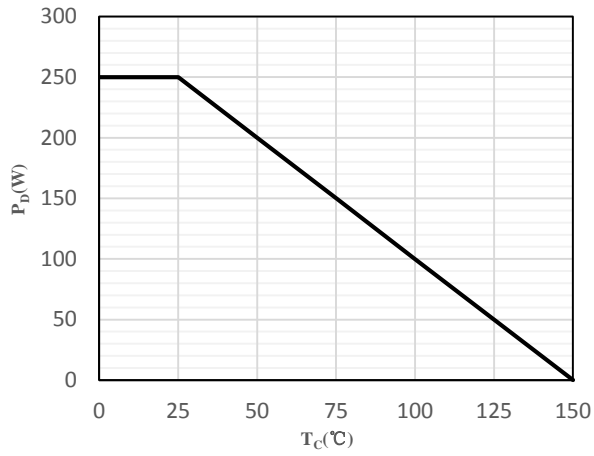

Fig 1 Power Dissipation

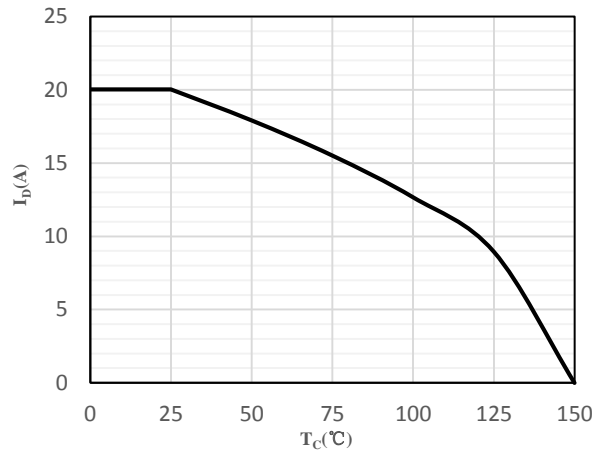

Fig 2 Drain Current

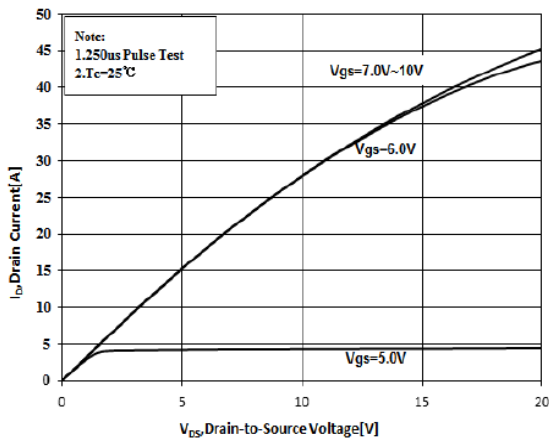

Fig 3 Typical Output Characteristics

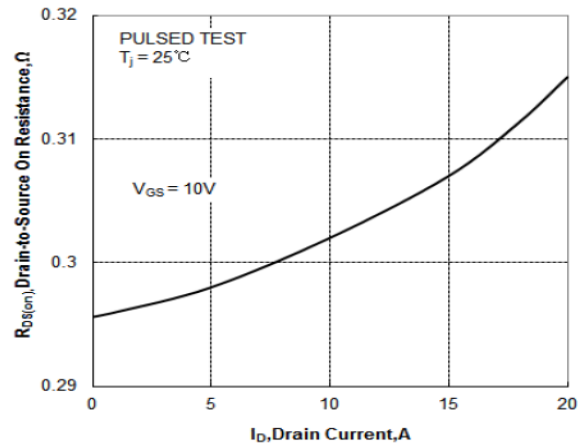

Fig 4 On-Resistance vs. Drain Current and Gate Voltage

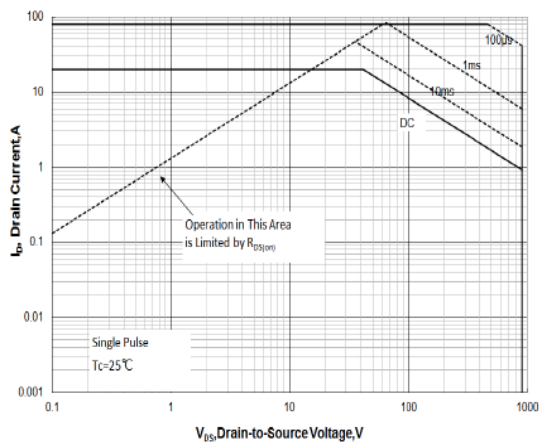

Fig 5 Safe Operation Area

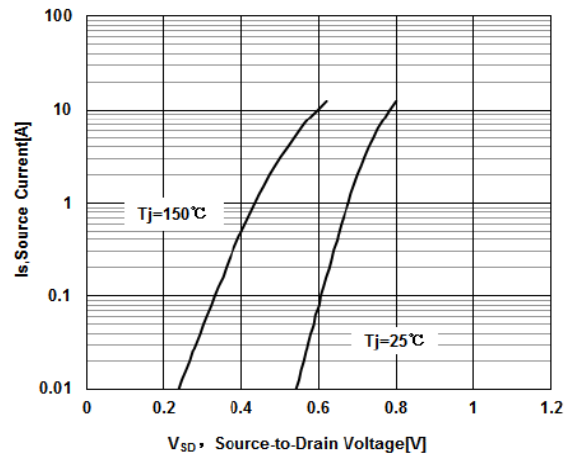

Fig 6 Body-Diode Characteristics

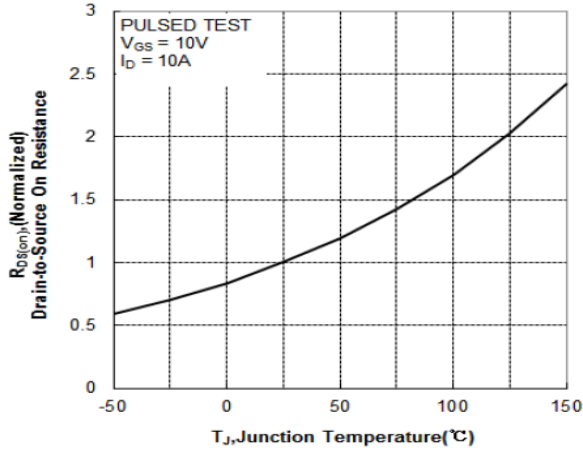

Fig 7 Normalized On-Resistance vs. Junction Temperature

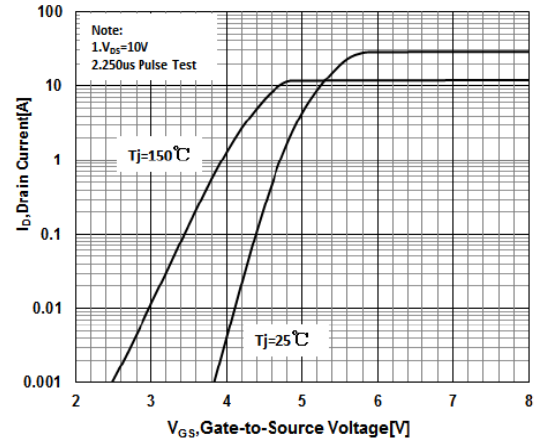

Fig 8 Transfer Characteristics

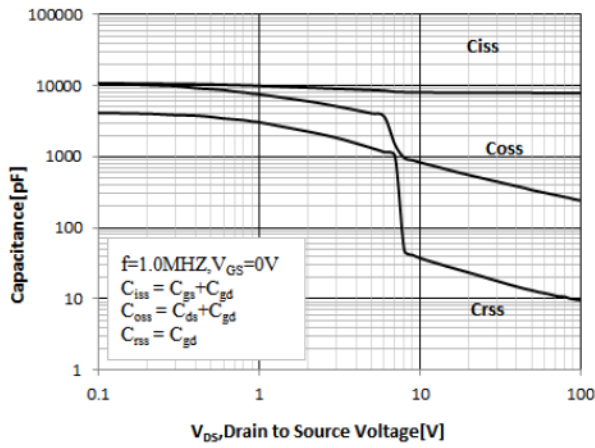

Fig 9 Capacitance Characteristics

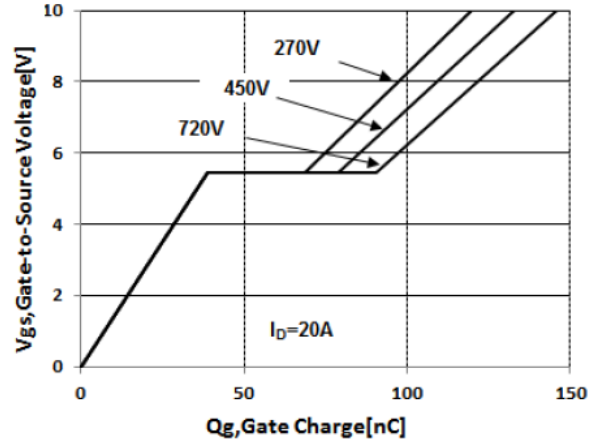

Fig 10 Gate-Charge Characteristics

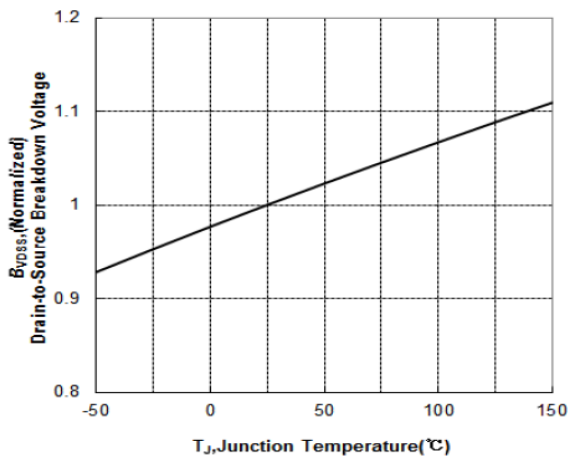

Fig 11 Normalized Breakdown Voltage vs. Junction Temperature

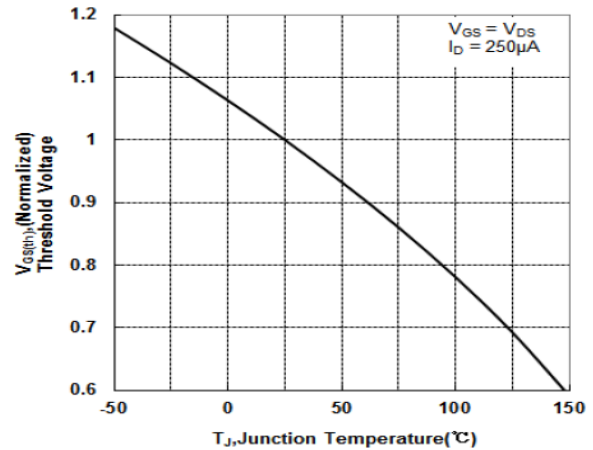
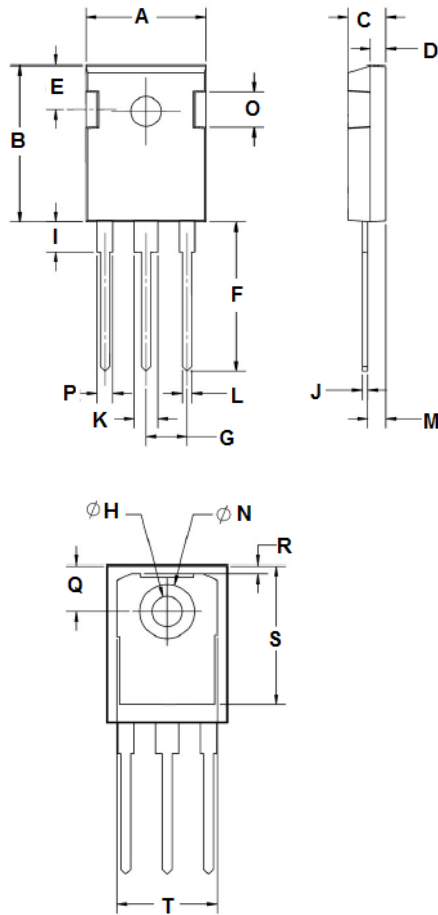

Fig 12 Normalized $V_{GS(th)}$ vs. Junction Temperature

Package Outline Dimensions (Unit: mm)



TO-247		
Dimension	Min.	Max.
A	15.50	16.10
B	20.70	21.30
C	4.70	5.30
D	1.80	2.20
E	5.20	5.80
F	19.70	20.30
G	5.20	5.60
H	3.30	3.70
I	3.90	4.30
J	0.50	0.70
K	2.80	3.20
L	1.00	1.40
M	2.20	2.60
N	7.00	7.20
O	4.90	5.30
P	1.80	2.20
Q	5.70	5.90
R	0.80	1.20
S	17.00	17.80
T	13.60	14.20