

### Features

- Fast switching
- Low  $R_{DS(ON)}$
- Low gate charge
- Low Reverse transfer capacitances

HF

### Mechanical Data

- Case: TO-247
- Molding Compound: UL Flammability Classification Rating 94V-0
- Terminals: Matte tin-plated leads; solderability-per MIL-STD-202, Method 208

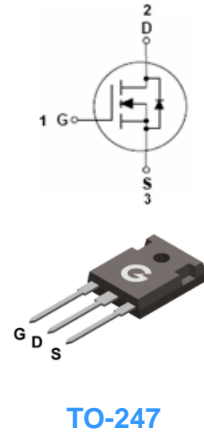

### Ordering Information

Part Number	Package	Shipping Quantity	Marking Code
BL20N50U	TO-247	30 pcs / Tube	20N50U

### Maximum Ratings (@ $T_C = 25^\circ\text{C}$ unless otherwise specified)

Parameter	Symbol	Value	Unit
Drain-to-Source Voltage	$V_{DSS}$	500	V
Gate-to-Source Voltage	$V_{GSS}$	$\pm 30$	V
Continuous Drain Current ( $T_C = 25^\circ\text{C}$ )	$I_D$	20	A
Continuous Drain Current ( $T_C = 100^\circ\text{C}$ )		12.5	A
Pulsed Drain Current ( $t_p = 10\mu\text{s}$ , $T_C = 25^\circ\text{C}$ )	$I_{DM}$	80	A
Single Pulse Avalanche Energy <sup>2</sup>	$E_{AS}$	1000	mJ
Power Dissipation ( $T_C = 25^\circ\text{C}$ )	$P_D$	250	W
Operating Junction Temperature Range	$T_J$	-55 ~ +150	$^\circ\text{C}$
Storage Temperature Range	$T_{STG}$	-55 ~ +150	$^\circ\text{C}$

### Thermal Characteristics

Parameter	Symbol	Min.	Typ.	Max.	Unit
Thermal Resistance Junction-to-Case	$R_{\theta JC}$	-	-	0.5	$^\circ\text{C/W}$
Thermal Resistance Junction-to-Air	$R_{\theta JA}$	-	-	40	$^\circ\text{C/W}$

### Electrical Characteristics (@ $T_A = 25^\circ\text{C}$ unless otherwise specified)

Symbol	Parameter	Test Condition	Min.	Typ.	Max.	Unit
<b>Static Characteristics</b>						
$V_{DSS}$	Drain-Source Breakdown Voltage	$V_{GS} = 0V, I_D = 250\mu A$	500	-	-	V
$I_{DSS}$	Zero Gate Voltage Drain Current	$V_{DS} = 500V, V_{GS} = 0V$	-	-	1	$\mu A$
$I_{GSS}$	Gate-Body Leakage Current	$V_{GS} = \pm 30V, V_{DS} = 0V$	-	-	$\pm 100$	nA
<b>On Characteristics</b>						
$R_{DS(ON)}$	Drain-Source On-resistance <sup>*1</sup>	$V_{GS} = 10V, I_D = 10A$	-	-	0.3	$\Omega$
$V_{GS(th)}$	Gate Threshold Voltage	$V_{DS} = V_{GS}, I_D = 250\mu A$	2	-	4	V
<b>Dynamic Characteristics</b>						
$C_{ISS}$	Input Capacitance	$V_{GS} = 0V$	-	2919	-	pF
$C_{OSS}$	Output Capacitance	$V_{DS} = 25V$	-	277	-	
$C_{RSS}$	Reverse Transfer Capacitance	$f = 1.0MHz$	-	16	-	
<b>Switching Characteristics</b>						
$t_{d(ON)}$	Turn-on Delay Time <sup>*3</sup>	$V_{DD} = 250V$ $I_D = 20A$ $R_G = 10\Omega$	-	34	-	ns
$t_r$	Turn-on Rise Time <sup>*3</sup>		-	65	-	
$t_{d(OFF)}$	Turn-Off Delay Time <sup>*3</sup>		-	82	-	
$t_f$	Turn-Off Fall Time <sup>*3</sup>		-	45	-	
$Q_G$	Total Gate-Charge	$V_{DD} = 400V$	-	52	-	nC
$Q_{GS}$	Gate to Source Charge	$V_{GS} = 10V$	-	13	-	
$Q_{GD}$	Gate to Drain (Miller) Charge	$I_D = 20A$	-	19	-	
<b>Source-Drain Diode Characteristics</b>						
$V_{SD}$	Diode Forward Voltage <sup>*1</sup>	$I_{SD} = 20A, V_{GS} = 0V$	-	-	1.5	V
$t_{rr}$	Reverse Recovery Time	$I_S = 20A, V_{GS} = 0V$	-	535	-	ns
$Q_{rr}$	Reverse Recovery Charge	$di/dt = 100A/\mu s$	-	5.7	-	$\mu C$

Notes:

1. The data tested by pulsed, pulse width  $\leq 300\mu s$ , duty cycle  $\leq 2\%$
2. The  $E_{AS}$  data shows Max. rating. The test condition is  $V_{DD} = 100V, V_{GS} = 15V, L = 10mH$
3. Guaranteed by design, not subject to production testing

Ratings and Characteristics Curves (@  $T_A = 25^\circ\text{C}$  unless otherwise specified)

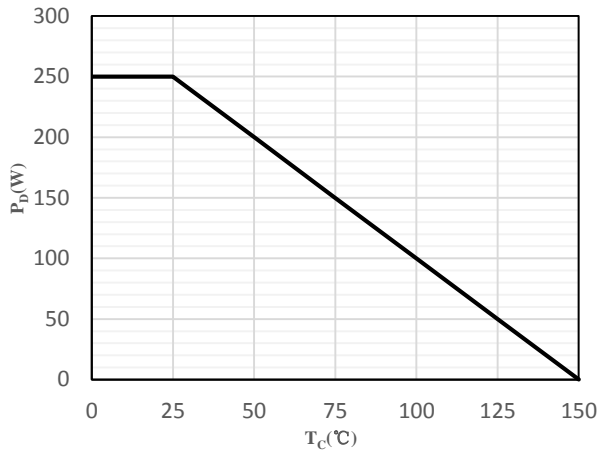

Fig 1 Power Dissipation

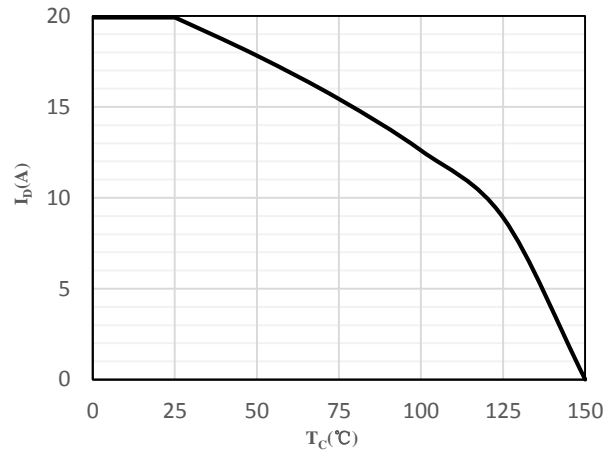

Fig 2 Drain Current

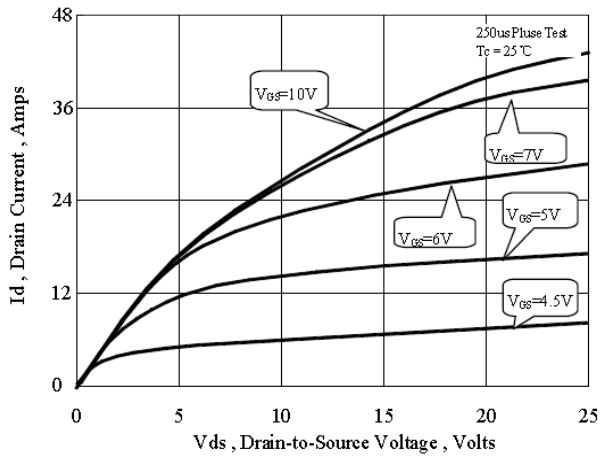

Fig 3 Typical Output Characteristics

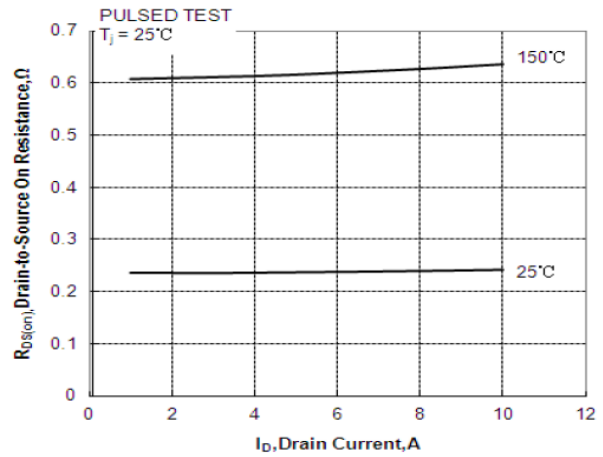

Fig 4 On-Resistance vs. Drain Current and Gate Voltage

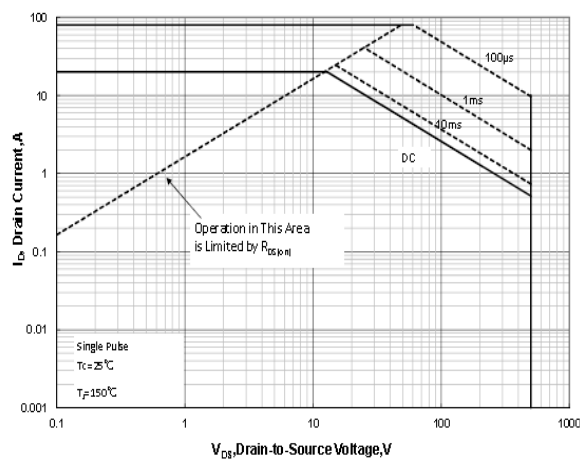

Fig 5 Safe Operation Area

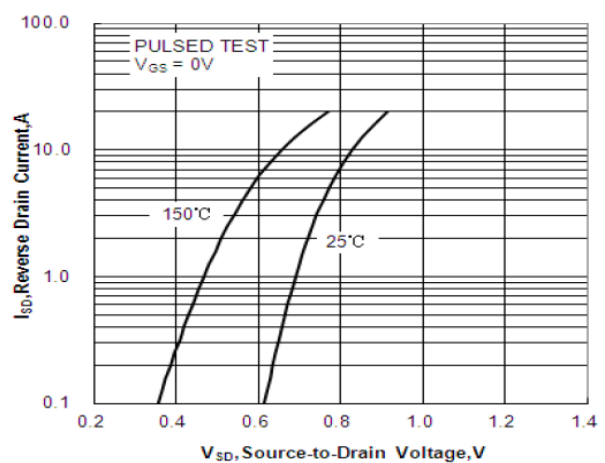

Fig 6 Body-Diode Characteristics

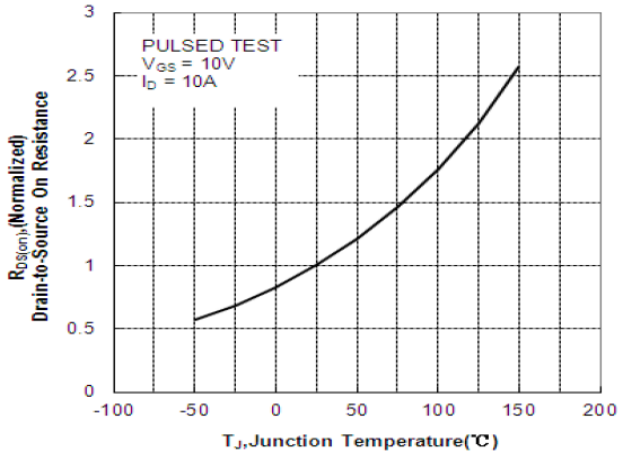

Fig 7 Normalized On-Resistance vs. Junction Temperature

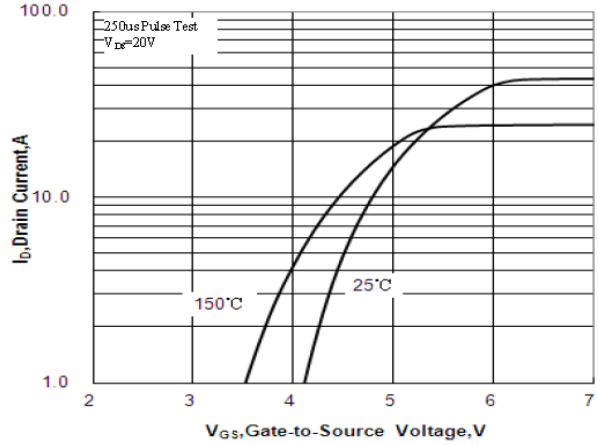

Fig 8 Transfer Characteristics

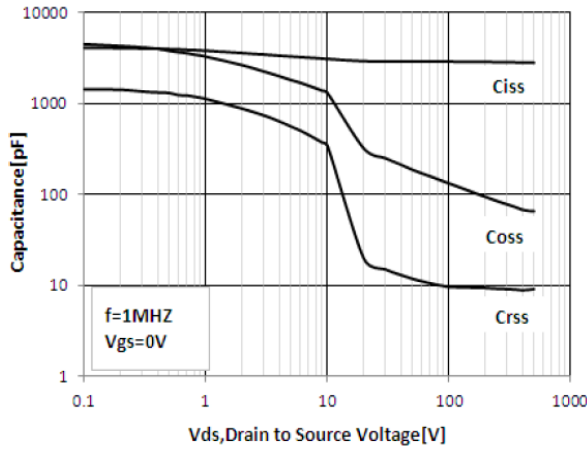

Fig 9 Capacitance Characteristics

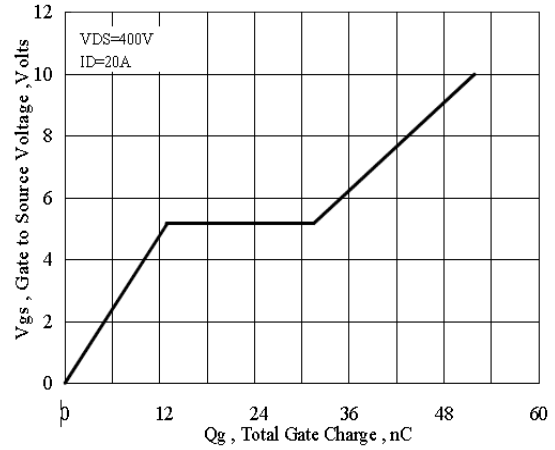

Fig 10 Gate-Charge Characteristics

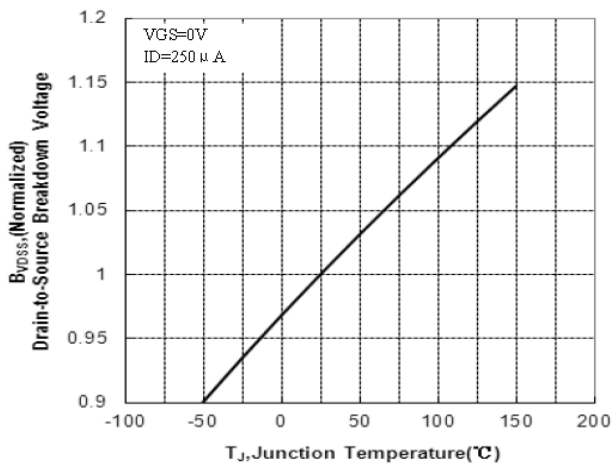

Fig 11 Normalized Breakdown Voltage vs. Junction Temperature

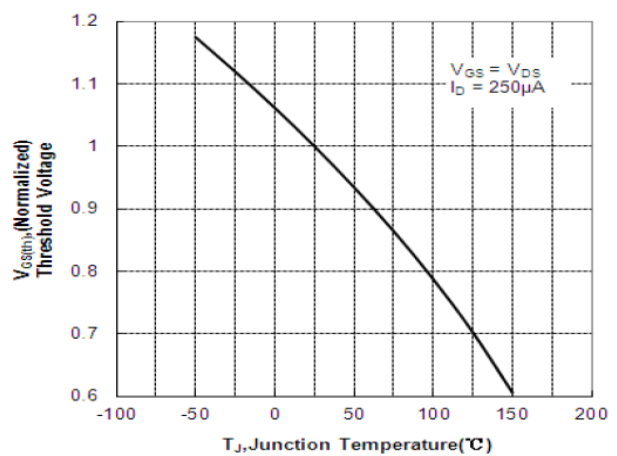
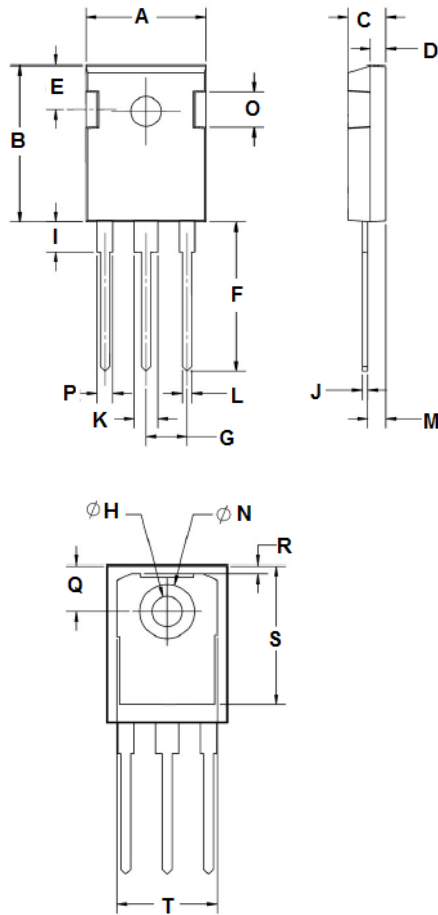

Fig 12 Normalized  $V_{GS(th)}$  vs. Junction Temperature

**Package Outline Dimensions** (Unit: mm)



TO-247		
Dimension	Min.	Max.
A	15.50	16.10
B	20.70	21.30
C	4.70	5.30
D	1.80	2.20
E	5.20	5.80
F	19.70	20.30
G	5.20	5.60
H	3.30	3.70
I	3.90	4.30
J	0.50	0.70
K	2.80	3.20
L	1.00	1.40
M	2.20	2.60
N	7.00	7.20
O	4.90	5.30
P	1.80	2.20
Q	5.70	5.90
R	0.80	1.20
S	17.00	17.80
T	13.60	14.20

**Important Notice**

Changzhou Galaxy Century Microelectronics (GME) reserves the right to make changes without further notice to any product information (copyrighted) herein to make corrections, modifications, improvements, or other changes. GME does not assume any liability arising out of the application or use of any product described herein; neither does it convey any license under its patent rights, nor the rights of others.